

SEALING TECHNOLOGY

Road Construction and Maintenance









denso-group.com

PRODUCTS



Products & Solutions

Overview of brands	3
Product finder	4-5
Fields of application	6-7

Bitumen joint tapes



 TOK®-Band Spezial	10
hot-applied	
 TOK®-Band A	11
activatable	
 TOK®-Band SK	12
self-adhesive	
 TOK®-Band SK N2	14
self-adhesive, for low temperatures	
 TOK®-Band SK Mark	15
self-adhesive and profiled	
 TOK®-Band SK Drain	16
for porous asphalt, self-adhesive	
 TOK®-Band SK DR	20
triangular, hot-applied or self-adhesive	

Mechanically extruded bitumen joint tape



 TOK®-Riegel	24
bitumen joint sealing	
 TOKOMAT®	25
application system	

Pouring compounds



hot-applied and stable:

 TOK®-Sil Resist	30
horizontal and vertical joints, stable	
 TOK®-Melt N1	31
horizontal joints, plastic	







cold-applied:

 DENSOLASTIC®-KU	34
for manhole covers and similar applications	
 DENSOLASTIC®-SV	36
for sensor slots and similar applications	
 DENSOLASTIC®-VT	37
sealing compound for pollution prevention	



Joint seam adhesives

 TOK®-Plast	40
cold plastic compound	
 PLASTOMAT®	41
application system	



Mortars, compounds, profiles & reinforcement

 DENSOLASTIC®-EM	46
permanently elastic plastic mortar	
 TOK®-Crete 45	50
mineral repair compound, high early strength	
 TOK®-Dur	52
Coating and levelling compounds	
 TOK®-Rep	54
road repair compound	
 TOK®-SK Rissband	55
Self-adhesive bituminous profile strip used to repair cracks	
 TOK®-Band Spezial Rundstrang	56
bitumen round profile for cracks and for sealing faulty cuts	
 TOK®-Armabit SK	57
asphalt reinforcement, self-adhesive	





Repair asphalt

 TOK®-Fill	60
conventional curing system	
 TOK®-Fill Aqua	61
reactive, fast-curing system	

Track construction

 DENSOLASTIC®-SU	64-66
rail embedding compounds	
 TOK®-Melt SU	67
bituminous rail embedding compound	

Civil engineering

 DENSO®-Gleitmittel	70
for use on mechanical seals in concrete pipes and manhole components	
 TOK®-Strip	71
for manhole components and special profiles made of concrete	
 FERMADUR®-C	72
compression seal for UV stressed joints	
 FERMADUR®-S	73
compression seal for underground joints	
 TOK®-BSW System	74
joint sealing solution for protective walls	

DENSO

100-year success story	76-77
Corrosion Prevention	78-79
Contact	80

RELIABLE PRODUCTS FOR LONG-LASTING ROADS

in road and track construction and civil engineering



9

Bitumen joint tapes

-  TOK®-Band Spezial
-  TOK®-Band A
-  TOK®-Band SK
-  TOK®-Band SK N2
-  TOK®-Band SK Mark
-  TOK®-Band SK Drain
-  TOK®-Band SK DR
-  TOKOMAT®
-  TOK®-Riegel



45

Mortars, compounds, profiles & reinforcement

-  DENSOLASTIC®-EM
-  TOK®-Crete 45
-  TOK®-Dur
-  TOK®-Rep
-  TOK®-SK Rissband
-  TOK®-Band Spezial Rundstrang
-  TOK®-Armabit SK



27

Pouring compounds

-  TOK®-Sil Resist
-  TOK®-Melt N1
-  DENSOLASTIC®-KU, -SV, -VT



59

Repair asphalt

-  TOK®-Fill
-  TOK®-Fill Aqua



38





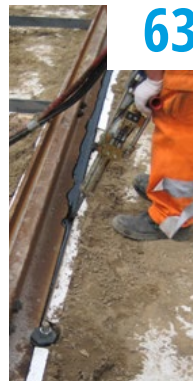

Joint seam adhesives

-  TOK®-Plast
-  PLASTOMAT®



63

Track construction & civil engineering

-  DENSOLASTIC®-SU
-  TOK®-Melt SU
-  DENSO®-Gleitmittel
-  TOK®-Strip
-  FERMADUR®-C
-  FERMADUR®-S
-  TOK®-BSW System

PRODUCT FINDER

Product *	Product Property			Tested in accordance to			Application temperature (environment)		Product application		Page
	strong	elastic/ stretchable	Shore hardness	ZTV Fug-StB	DIN EN 14188-1	VDV 6201	min. °C (°F)	max. °C (°F)	cold	warm	
TOK®-Bitumen joint tapes											
TOK®-Band Spezial		✓		✓			+5 (+41)	+50 (+122)		✓	10
TOK®-Band Spezial Rundstrang		✓		✓			+5 (+41)	+50 (+122)		✓	56
TOK®-Band A		✓		✓			+5 (+41)	+35 (+95)		✓	11
TOK®-Band SK		✓		✓			+5 (+41)	+50 (+122)	✓		12
TOK®-Band SK N2		✓		✓			0 (+32)	+35 (+95)	✓		14
TOK®-Band SK Mark		✓		✓			+5 (+41)	+50 (+122)	✓		15
TOK®-Band SK Drain		✓		✓			+5 (+41)	+50 (+122)	✓		16
TOK®-Band SK DR		✓		✓			+5 (+41)	+50 (+122)	✓		20
TOK®-SK Rissband		✓		✓			+5 (+41)	+50 (+122)	✓		55
TOKOMAT® / TOK®-Riegel		✓		✓			0 (+32)	+35 (+95)		✓	24
TOK®-seam adhesive & Repair asphalt											
TOK®-Plast	✓						+5 (+41)	+50 (+122)	✓		40
TOK®-Fill	✓						-10 (+14)	+25 (+77)	✓		60
TOK®-Fill Aqua	✓						-10 (+14)	+45 (+113)	✓		61
TOK®-repairing mortar, coating compound, reinforcement											
TOK®-Rep	✓						+5 (+41)	+50 (+122)	✓		54
TOK®-Crete 45	✓						-10 (+14)	+30 (+86)	✓		50
TOK®-Dur		✓					+5 (+41)	+40 (+104)	✓		52
TOK®-Armabit SK		✓					+5 (+41)	+30 (+86)	✓		57
TOK®-Sealants											
TOK®-Sil Resist		✓			✓		0 (+32)	+40 (+104)		✓	30
TOK®-Strip							0 (+32)	+35 (+95)	✓		71
TOK®-BSW System		✓			✓		0 (+32)	+40 (+104)		✓	74
DENSOLASTIC®-cold-applied											
DENSOLASTIC®-EM		✓	A 65-70				+5 (+41)	+40 (+104)	✓		46
DENSOLASTIC®-KU		✓	A 65				+5 (+41)	+40 (+104)	✓		34
DENSOLASTIC®-SU		✓	A 45-85			✓	+5 (+41)	+35 (+95)	✓		64
DENSOLASTIC®-SV	✓		D 70-75				+5 (+41)	+40 (+104)	✓		36
DENSOLASTIC®-VT		✓	A 18-20				+5 (+41)	+40 (+104)	✓		37
FERMADUR®-Compression seals											
FERMADUR®-C		✓	A 30-35				-10 (+14)	+50 (+122)	✓		72
FERMADUR®-S		✓	A 30-35				-10 (+14)	+50 (+122)	✓		73
DENSO®-Sewer construction											
DENSO®-Gleitmittel (lubricant)	✓						-10 (+14)	+50 (+122)	✓		70

*The overview shows a selection of the extensive product range without the promise of any product features. The product properties can be found in the specific product information.

Product*	Product characteristic	Product characteristic						Page
		Joints in asphalt	Joints in concrete	Tram construction	Sealing protection walls	Repair of road surfaces and runways	Channel and shaft seals	
TOK®-Bitumen joint tapes								
TOK®-Band Spezial	hot-applied	✓						10
TOK®-Band Spezial Rundstrang	meltable, for sealing cracks	✓						56
TOK®-Band A	activatable	✓						11
TOK®-Band SK	self-adhesive	✓						12
TOK®-Band SK N2	self-adhesive, for low temperatures	✓		✓				14
TOK®-Band SK Mark	self-adhesive, profiled	✓						15
TOK®-Band SK Drain	self-adhesive, for porous asphalt	✓						16
TOK®-Band SK DR	self-adhesive, triangular profile	✓						20
TOK®-SK Rissband	self-adhesive, for cracks	✓						55
TOKOMAT® / TOK®-Riegel	automatic extrusion	✓		✓	✓			24
TOK®--seam adhesive & repair asphalt								
TOK®-Plast	thixotrope	✓(Joints)						40
TOK®-Fill	normal curing					✓		60
TOK®-Fill Aqua	reactive curing					✓		61
TOK®-repairing mortar/coating compound/asphalt reinforcement								
TOK®-Rep	quick setting time					✓		54
TOK®-Crete 45	all weather usage, high pressure-resistant					✓		50
TOK®-Dur	quickly ready for traffic					✓		52
TOK®-Armabit SK	according to DIN EN 15381					✓		57
TOK®-Sealants								
TOK®-Sil Resist	horizontal and vertical usage	✓	✓				✓	30
TOK®-Strip	self-adhesive						✓	71
TOK®-BSW System	uv-resistant		✓		✓			74
DENSOLASTIC®-cold-applied								
DENSOLASTIC®-EM	dynamic claimable						✓	46
DENSOLASTIC®-KU	noise reducing						✓	34
DENSOLASTIC®-SU	vibration-reducing			✓				64
DENSOLASTIC®-SV	for sensor- and induction loops	✓	✓			✓		36
DENSOLASTIC®-VT	for WHG (Water Resources Law) areas, LAU-permission	✓	✓					37
FERMADUR®-Compression seals								
FERMADUR®-C	for UV and ozone stressed joints		✓		✓			72
FERMADUR®-S	for underground joints		✓		✓			73
DENSO®-Sewer construction								
DENSO®-Lubricant	optimum lubrication						✓	70

*The overview shows a selection of the extensive product range without the promise of any product features. The product properties can be found in the specific product information.

FIELDS OF APPLICATION

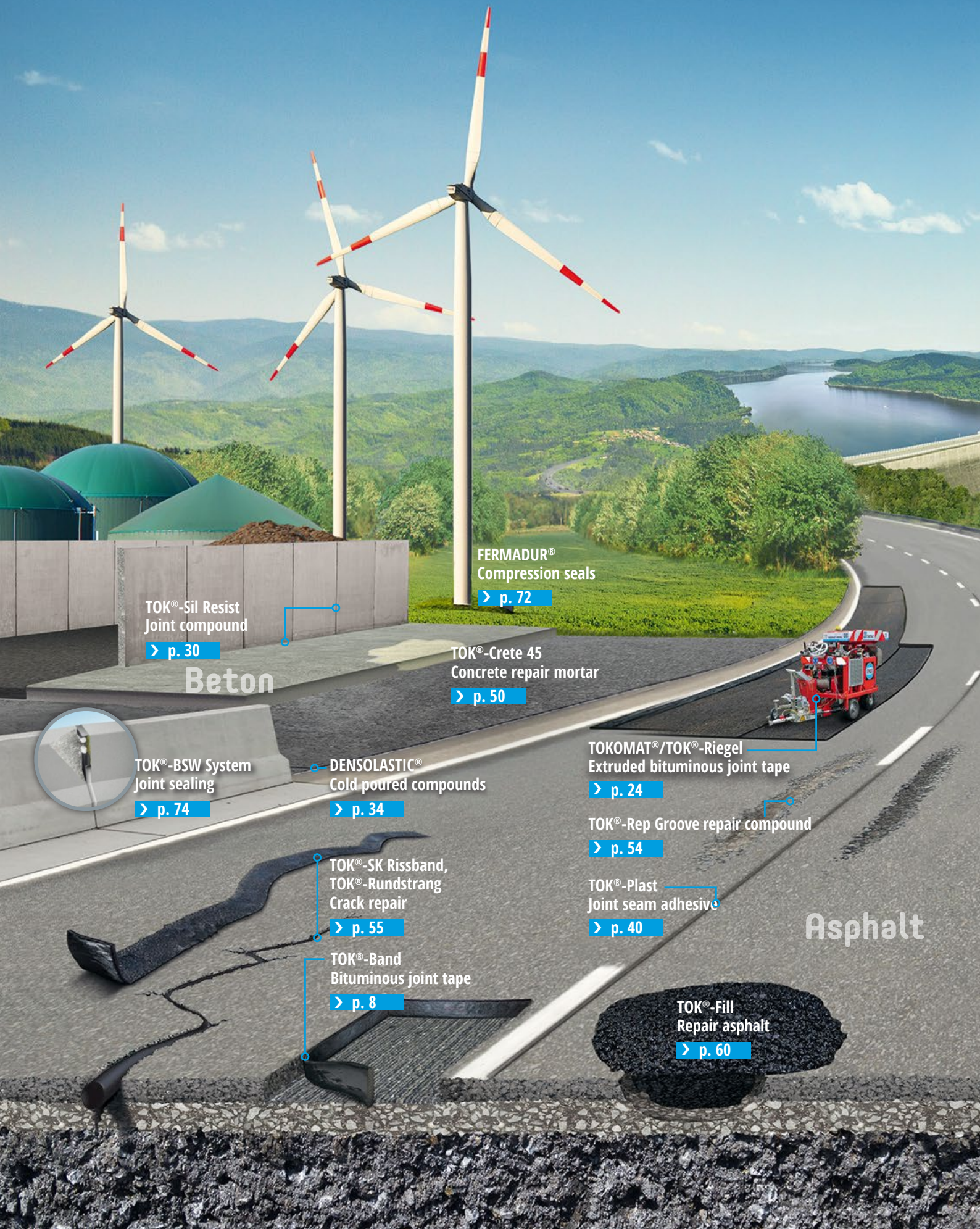

TOK®-Sil Resist
Joint compound

> p. 30

Beton

FERMADUR®
Compression seals

> p. 72

TOK®-Crete 45
Concrete repair mortar

> p. 50

TOK®-BSW System
Joint sealing

> p. 74

DENSOLASTIC®
Cold poured compounds

> p. 34

TOK®-SK Rissband,
TOK®-Rundstrang
Crack repair

> p. 55

TOK®-Band
Bituminous joint tape

> p. 8

TOKOMAT®/TOK®-Riegel
Extruded bituminous joint tape

> p. 24

TOK®-Rep Groove repair compound

> p. 54

TOK®-Plast
Joint seam adhesive

> p. 40

Asphalt

TOK®-Fill
Repair asphalt

> p. 60



FERMADUR®
Compression seals
> p. 72

DENSOLASTIC®-SV
Pouring compound for sensor slits
> p. 36

TOK®-Armabit SK
Asphalt reinforcement
> p. 57

TOK®-Dur
Coating compound
> p. 52

TOK®-Melt
Hot poured compounds
> p. 31

DENSOLASTIC®-EM
High stable elastic synthetic mortar
> p. 46

TOK®-Strip
Shaft sealing
> p. 71

TOK®-Riegel,
TOK®-Band SK N2
Bituminous joint tape
for rails
> p. 24 > p. 14

TOK®-Melt SU
Bituminous underlay
pouring compound
> p. 67

DENSOLASTIC®-SU
PU-Embedding compound
> p. 64

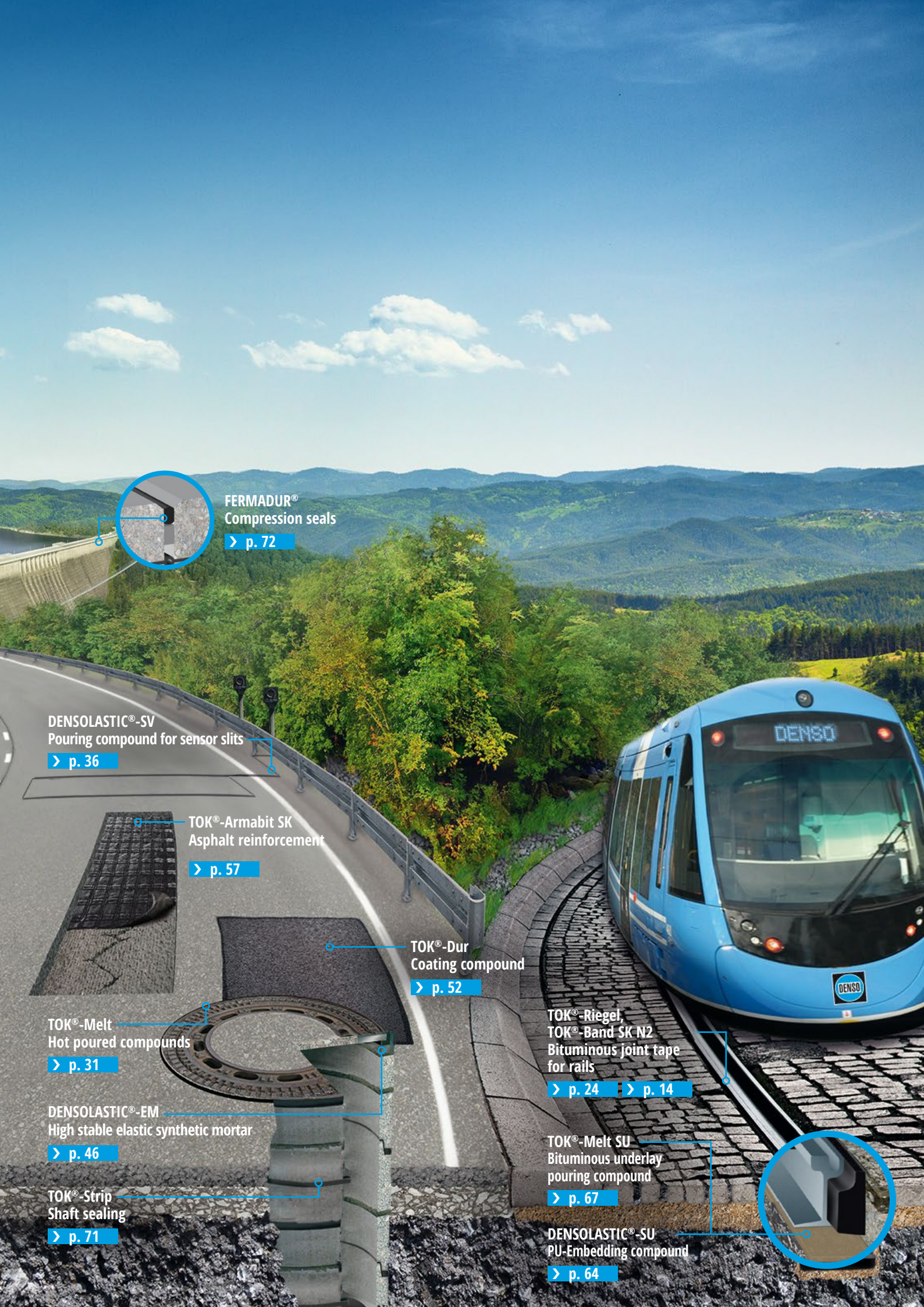
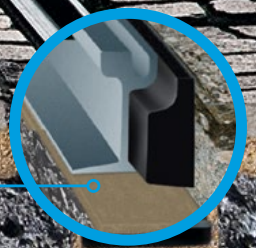

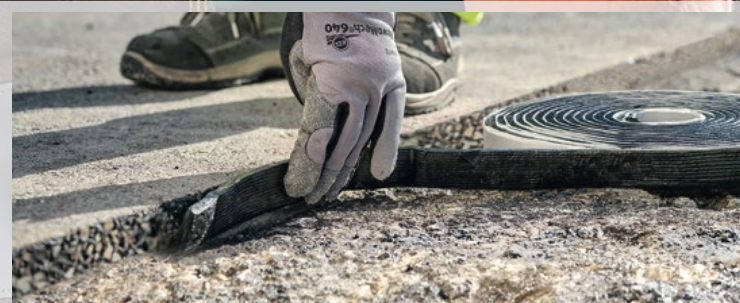

TOK®-Band SK

Successful self-adhesive,
time saving & safe



TOK®-Band A

Very fast activation -
Applied in seconds



TOK®-Band SK N2

Flexible even at
very low temperatures



TOK®-BAND

Bitumen joint tapes

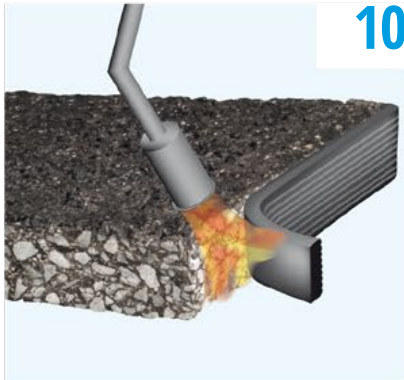

TOK®-Band Spezial

Meltable bitumen joint tape for joints and seams in asphalt road construction.



TOK®-Band A

Bitumen joint tape that can be **activated**, for joints and seams in asphalt road construction.



TOK®-Band SK

Self-adhesive bitumen joint tape for joints and seams in asphalt road construction



TOK®-Band SK N2

Self-adhesive and highly elastic bitumen joint tape. Ideal for use at low temperatures.



TOK®-Band SK Mark

Self-adhesive bitumen joint tape with protrusion profiling for joints and seams in asphalt road construction.



TOK®-Band SK Drain

Self-adhesive bitumen joint tape for joints and connections in porous asphalt road surfaces.



TOK®-Band SK DR

A bitumen joint tape in a **triangular profile** which is **meltable** or **self-adhesive**.

TOK®-Band Spezial

Meltable bitumen joint tape for joints and seams in asphalt road construction.

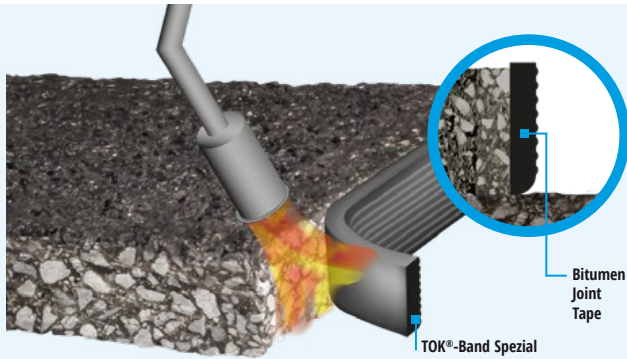

Easy to apply with burner.



Fulfils all requirements of ZTV Fug-StB 15.



Processing temperature from +5°C to +50°C (from +41°F to +122°F).

TOK®-Band Spezial is a high-quality bitumen joint tape made from polymer-improved road bitumen with exceptional stretch and adhesion properties. The smooth side of the bitumen joint tape is the side that is melted onto the joint edge.

TOK®-Band Spezial and its primer, **CORRISOL®-Spezial**, have been tested in accordance with TL/TP Fug-StB and meet all the requirements of these regulations.

Usage

TOK®-Band Spezial is ideal for sealing joints in asphalt road construction. In accordance with ZTV Fug-StB, it is also used on components such as concrete curbs and gutters where hot mix is subsequently applied on top.

Thanks to its outstanding material properties, permanent and fully sealed joints are guaranteed.

Application

Weather conditions:

In accordance with ZTV Fug-StB, bitumen joint tapes may only be applied in dry weather and when the surface temperature of the asphalt is at least +5°C (+41°F). At temperatures between 0°C and +5°C (+30°F and +41°F), the product may only be applied if additional measures are taken (e.g. preheating of edges).

Requirements for connection edges:

In accordance with ZTV Fug-StB, the following basic requirements apply: Edge surfaces must be solid, even and straight for the successful application of bitumen joint tape. The connection edges must be bevelled, precision-milled or cut, or assembled using ready-made components. They must be free of dirt. Rust particles on steel components must be removed. Any residual dirt left adhering to the surface must be removed with a wire brush or compressed air. The edges must be dry.

Use of TOK®-Band Spezial:

If all of the requirements for connection edges are fully satisfied, **TOK®-Band Spezial** may be applied to the edge. The primer **CORRISOL®-Spezial** must be applied to the joint edge first. In accordance with ZTV Fug-StB, only the primer that has been tested for

use in conjunction with this bitumen joint tape may be used. The bitumen-based primer **CORRISOL®-Spezial** was developed specifically for use with **TOK®-Band Spezial**. In summer, the drying time of the primer is approximately 20 minutes, depending on weather conditions.

Application:

Before application, the joint tape is laid out with the anti-adhesive paper upwards. The anti-adhesive paper should be removed just before the tape is laid. The smooth side of the meltable **TOK®-Band Spezial** is melted using the gas burner and then pressed onto the joint edge.

ZTV Fug-StB 15 – bitumen joint tapes:

In accordance with ZTV Fug-StB, bitumen joint tape must be laid with a 5-mm protrusion on rolled asphalt surface layers, so that a so-called 'rivet head' is produced when rolling the asphalt. This forms an additional seal on the surface and provides a clean 'closure'. In cast asphalt surfaces, the joint tape is laid flush to the edge. The width of the joint tape must be at least **10 mm**. In accordance with ZTV Fug-StB and TL Fug-StB, the quality of the material must be monitored by a third party and verified by placing an approval label on the packaging.

Typical Product Properties (Excerpt*)

Test	Unit	Typical results range	Requirement
Softening point (Ring&Ball method)	°C / °F	> +100 (+212)	> +90 (+194)
Cone penetration	0.1 mm	20 - 50	20 - 50
Recovery	%	10 - 30	10 - 30
Cold bending behaviour	°C / °F	≤ ±0 (+32)	≤ ±0 (+32)
Stretch and adhesive strength	% / N/mm ²	≥ 10 / ≤ 1,0	≥ 10 / ≤ 1,0

* For more product information as well as details on ordering and packaging, please refer to the product data sheet at denso-group.com.

TOK®-Band A

Bitumen joint tape with activation layer for joints and seams in asphalt road construction.

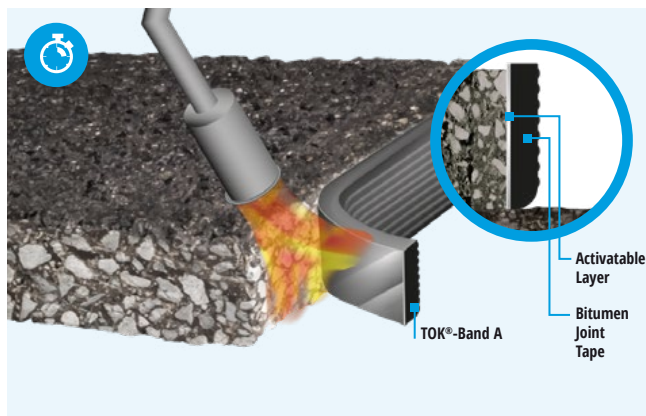

Can be applied in seconds.



No primer required.



Fulfils all requirements of ZTV Fug-StB 15.



Processing temperature from +5°C to +50°C
(from +41°F to +122°F)

TOK®-Band A is a high-quality bitumen joint tape made from polymer-improved road bitumen with exceptional stretch and adhesion properties. **TOK®-Band A** has a homogeneous full-surface coating on one side, which is largely non-adhesive at temperatures of approximately -20°C to +30°C (-4°F to +86°F). This coating (smooth side of the bitumen joint tape) can be activated by briefly applying heat, for example using a gas burner.

After activation, the coating remains highly adhesive for a long period of time, ensuring that the joint tape securely adheres to the properly prepared edge. There is no need to apply primer.

The slightly profiled (wavy) side of the bitumen tape is the side without the activatable coating. This side will later form the base for the 'hot' asphalt mix.

If necessary, the optional primer **TOK®-SK Primer** can be used to boost the adhesion of **TOK®-Band A** to the joint edge

Usage

TOK®-Band A ideal for sealing joints in asphalt road construction. In accordance with ZTV Fug-StB, it is also used on components such as concrete curbs and gutters where hot

mix is subsequently applied on top. Thanks to its outstanding material properties, permanent and fully sealed joints are guaranteed.

Application

Weather conditions:

In accordance with ZTV Fug-StB, bitumen joint tapes may only be applied in dry weather and when the surface temperature of the asphalt is at least +5°C (+41°F).

At temperatures between 0°C and +5°C (+30°F and +41°F), the product may only be applied if additional measures are taken (e.g. preheating of edges).

Requirements for connection edges:

In accordance with ZTV Fug-StB, the following basic requirements apply:

Edge surfaces must be solid, even and straight for the successful application of bitumen joint tape. The connection edges must be bevelled, precision-milled or cut, or assembled using ready-made components.

They must be free of dirt. Rust particles on steel components must be removed.

Any residual dirt left adhering to the surface must be removed with a wire brush or compressed air. The edges must be dry.

Use of TOK®-Band A:

If all of the requirements for connection edges are fully satisfied, **TOK®-Band A** may be applied to the edge without primer.

The relevant test results in accordance with TL/TP Fug-StB are available.

If necessary, you can optimise the adhesion of the bitumen joint tape to the edge by applying **TOK®-SK Primer**. In accordance with ZTV Fug-StB, only the primer that has been tested for use in conjunction with this bitumen joint tape may be used.

In summer, the drying time of **TOK®-SK Primer** is just 3 to 5 minutes, depending on weather conditions, allowing further work to start quickly.

Application:

TOK®-Band A is applied to the prepared connection edge with the coated (smooth) side facing upwards.

The anti-adhesive paper should be removed just before the tape is laid.

The coating (smooth side) of the laid **TOK®-Band A** is then activated using a gas burner. It is sufficient to hold the flame directly over the coating for approximately 1–3 seconds. The activated side of the bitumen joint tape will now remain highly adhesive for a period of time. The length of this period may differ depending on the temperature and will be shorter at lower temperatures.

At room temperature, the coating remains active for between 5 and 10 minutes.

Once the coating has been activated, the adhesive side of the tape is immediately pressed securely onto the connection edge by hand or using a tool.

ZTV Fug-StB 15 – bitumen joint tapes:

In accordance with ZTV Fug-StB, bitumen joint tape must be laid with a 5-mm protrusion on rolled asphalt surface layers, so that a so-called 'rivet head' is produced when rolling the asphalt. This forms an additional seal on the surface and provides a clean 'closure'.

In cast asphalt surfaces, the joint tape is laid flush to the edge.

The width of the joint tape must be at least 10 mm.

In accordance with ZTV Fug-StB and TL Fug-StB, the quality of the material must be monitored by a third party and verified by placing an approval label on the packaging.

Typical Product Properties (Excerpt*)

Test	Unit	Typical results range	Requirement
Softening point (Ring&Ball method)	°C / °F	> +100 (+212)	> +90 (+194)
Cone penetration	0.1 mm	20 - 50	20 - 50
Recovery	%	10 - 30	10 - 30
Cold bending behaviour	°C / °F	≤ ±0 (+32)	≤ ±0 (+32)
Stretch and adhesive strength	% / N/mm²	≥ 10 / ≤ 1,0	≥ 10 / ≤ 1,0

* For more product information as well as details on ordering and packaging, please refer to the product data sheet at denso-group.com.

TOK®-Band SK

Self-adhesive bitumen joint tape for joints and seams in asphalt road construction.

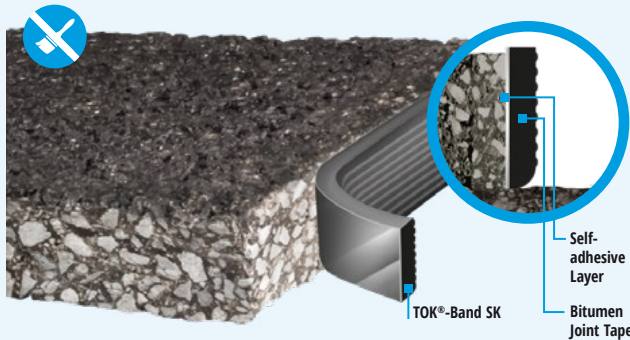

Cold processed – no burner required.



No primer required.



Fulfills all requirements of ZTV Fug-StB 15.



Processing temperature from +5°C to +50°C
(from +41°F to +122°F).

TOK®-Band SK is a high-quality bitumen joint tape made from polymer-improved road bitumen with exceptional stretch and adhesion properties. **TOK®-Band SK** has a homogeneous full-surface adhesive coating on one side (smooth side), and can therefore be applied to 'cold' joint edges quickly and safely, without the use of a gas burner.

TOK®-Band SK can be applied without primer to properly prepared edges that are clean, dry and free of dust. The slightly profiled (wavy) side of the bitumen tape is the side without an adhesive coating. This side will later form the base for the 'hot' asphalt mix. If necessary, the optional primer **TOK®-SK Primer** can be used to boost the adhesion of **TOK®-Band SK** to the joint edge.

Usage

TOK®-Band SK is ideal for sealing joints in asphalt road construction. In accordance with ZTV Fug-StB, it is also used on components such as concrete curbs and gutters where hot mix is subsequently applied on top.

Thanks to its outstanding material properties, permanent and fully sealed joints are guaranteed.

Application

Weather conditions:

In accordance with ZTV Fug-StB, bitumen joint tapes may only be applied in dry weather and when the surface temperature of the asphalt is at least +5°C (+41°F). At temperatures between 0°C and +5°C (+30°F and +41°F), the product may only be applied if additional measures are taken (e.g. preheating of edges).

Requirements for connection edges:

In accordance with ZTV Fug-StB, the following basic requirements apply: Edge surfaces must be solid, even and straight for the successful application of bitumen joint tape. The connection edges must be bevelled, precision-milled or cut, or assembled using ready-made components. They must be free of dirt. Rust particles on steel components must be removed. Any residual dirt left adhering to the surface must be removed with a wire brush or compressed air. The edges must be dry.

Use of TOK®-Band SK:

If all of the requirements for connection edges are fully satisfied, **TOK®-Band SK** may be applied to the edge without primer. The relevant test results in accordance with TL/TP Fug-StB are available.

If necessary, you can optimise the adhesion of the bitumen joint tape to the edge by applying **TOK®-SK Primer**.

In summer, the drying time of **TOK®-SK Primer** is just 3 to 5 minutes, depending on weather conditions, allowing further work to start quickly.

Application:

TOK®-Band SK is applied to the prepared connection edge with the adhesive layer (smooth side) facing upwards. The anti-adhesive paper should be removed just before the tape is laid. The adhesive surface (smooth side) of the laid **TOK®-Band SK** is pressed onto the connection edge by hand or using a tool.

ZTV Fug-StB 15 – bitumen joint tapes:

In accordance with ZTV Fug-StB, bitumen joint tape must be laid with a 5-mm protrusion on rolled asphalt surface layers, so that a so-called 'rivet head' is produced when rolling the asphalt. This forms an additional seal on the surface and provides a clean 'closure'. In cast asphalt surfaces, the joint tape is laid flush to the edge. The width of the joint tape must be at least 10 mm. In accordance with ZTV Fug-StB and TL Fug-StB, the quality of the material must be monitored by a third party and verified by placing an approval label on the packaging.

Typical Product Properties (Excerpt*)

Test	Unit	Typical results range	Requirement
Softening point (Ring&Ball method)	°C / °F	> +100 (+212)	> +90 (+194)
Cone penetration	0.1 mm	20 - 50	20 - 50
Recovery	%	10 - 30	10 - 30
Cold bending behaviour	°C / °F	≤ ±0 (+32)	≤ ±0 (+32)
Stretch and adhesive strength	% / N/mm ²	≥ 10 / ≤ 1,0	≥ 10 / ≤ 1,0

* For more product information as well as details on ordering and packaging, please refer to the product data sheet at denso-group.com.

TOK®-Band SK – Application

The proven self-adhesive bitumen profile to seal joints / connections



Excavation

Excavation of a cable trench carrier and binding layers are already installed. Only the top layer is missing.



Lay out the TOK®-Band

Lay out the joint tape and cut to length, if necessary.



Stick on TOK®-Band SK

Simply press the joint tape on the cleaned and prepared edge.



Pay attention to the overlap

Here ensure a protrusion of 5 mm. For cast asphalt, the protrusion is not required as it is not rolled afterwards.



Installed TOK®-Band SK

A cleanly installed joint tape.



Apply the pressure-sensitive adhesive

Spray the edge with pressure-sensitive adhesive, however do not spray the joint tape.



Install the mix

Install the mix so that it protrudes. Finally compact it using a roller or a vibrating plate. Here, the first roller pass should be on the joint connection.







Finished joint connection

This is what a professionally performed joint in the top layer looks like.

TOK®-Band SK N2

High-flexibility self-adhesive bitumen joint tape for joints and seams in asphalt road construction.



-  Excellent adhesion and elasticity at -10 °C (14 °F).
-  Cold processed – no burner required.
-  No primer required.
-  Fulfils all requirements of ZTV Fug-StB 15.
-  Processing temperature from 0 °C to +35°C (from +32 °F to +95 °F).

TOK®-Band SK N2 is a high-quality bitumen joint tape made from polymer-improved road bitumen with exceptional stretch and adhesion properties. **TOK®-Band SK N2** has a homogeneous full-surface adhesive coating on one side (smooth side), and can therefore be applied to 'cold' joint edges quickly and safely, without the use of a gas burner.

TOK®-Band SK N2 can be applied without primer to properly prepared edges that are clean, dry and free of dust. The slightly profiled (way) side of the bitumen tape is the side without an adhesive coating. This side will later form the base for the 'hot' asphalt mix. If necessary, the optional primer **TOK®-SK Primer** can be used to boost the adhesion of **TOK®-Band SK N2** to the joint edge.

Usage

TOK®-Band SK N2 is ideal for sealing joints in asphalt road construction applications that are subject to special or demanding requirements. One example is railway track construction, where the joints on the rails have to cope with a great deal of movement.

Thanks to its high flexibility, the tape is also ideal for use at low temperatures, where conventional bitumen joint tapes would be too stiff for easy application. When used in conjunction with **TOK®-SK Primer**, the product boasts an exceptional stretch capacity of $\geq 33\%$ at -10°C (+14°F). Even at temperatures as low as -20°C (-4°F), the adhesion and elasticity requirements specified for bitumen joint tape in TL Fug-StB 15 are satisfied or exceeded.

Application

Weather conditions:

In accordance with ZTV Fug-StB, bitumen joint tapes may only be applied in dry weather and when the surface temperature of the asphalt is at least +5°C (+41°F). At temperatures between 0°C and +5°C (+30°F and +41°F), the product may only be applied if additional measures are taken (e.g. preheating of edges).

Requirements for connection edges:

In accordance with ZTV Fug-StB, the following basic requirements apply: Edge surfaces must be solid, even and straight for the successful application of bitumen joint tape. The connection edges must be bevelled, precision-milled or cut, or assembled using ready-made components. They must be free of dirt. Rust particles on steel components must be removed. Any residual dirt left adhering to the surface must be removed with a wire brush or compressed air. The edges must be dry.

Use of TOK®-Band SK N2:

If all of the requirements for connection edges are fully satisfied, **TOK®-Band SK N2** may be applied to the edge without primer. The relevant test results in accordance with TL/TP Fug-StB are available.

If necessary, you can optimise the adhesion of the bitumen joint tape to the edge, and ensure that the adhesion and stretch requirements for hot pouring compounds are met in accordance with ZTV Fug-StB 15, by also applying **TOK®-SK Primer**. In summer, the drying time of **TOK®-SK Primer** is just 3 to 5 minutes, depending on weather conditions, allowing further work to start quickly.

Application:

TOK®-Band SK N2 is applied to the prepared connection edge with the adhesive layer (smooth side) facing upwards. The anti-adhesive paper should be removed just before the tape is laid. The adhesive surface (smooth side) of the laid **TOK®-Band SK N2** is pressed onto the connection edge by hand or using a tool.

ZTV Fug-StB 15 – bitumen joint tapes:

In accordance with ZTV Fug-StB, bitumen joint tape must be laid with a 5-mm protrusion on rolled asphalt surface layers, so that a so-called 'rivet head' is produced when rolling the asphalt. This forms an additional seal on the surface and provides a clean 'closure'. In cast asphalt surfaces, the joint tape is laid flush to the edge. The width of the joint tape must be at least 10 mm. In accordance with ZTV Fug-StB and TL Fug-StB, the quality of the material must be monitored by a third party and verified by placing an approval label on the packaging.

Typical Product Properties (Excerpt*)

Test	Unit	Typical results range	Requirement
Softening point (Ring&Ball method)	°C / °F	> +100 (+212)	> +90 (+194)
Cone penetration	0.1 mm	20 - 50	20 - 50
Recovery	%	10 - 30	10 - 30
Cold bending behaviour	°C / °F	$\leq \pm 0$ (+32)	$\leq \pm 0$ (+32)
Stretch and adhesive strength	% / N/mm ²	≥ 10 / $\leq 1,0$	≥ 10 / $\leq 1,0$

* For more product information as well as details on ordering and packaging, please refer to the product data sheet at denso-group.com.

TOK®-Band SK Mark

Self-adhesive bitumen joint tape with protrusion profiling for joints and seams in asphalt road construction.



Cold processed – no burner required.



No primer required.



Fulfils all requirements of ZTV Fug-StB 15.



Processing temperature from +5°C to +50°C
(from +41°F to +122°F)

TOK®-Band SK Mark is a high-quality bitumen joint tape made from polymer-improved road bitumen with exceptional stretch and adhesion properties. **TOK®-Band SK Mark** has a homogeneous full-surface adhesive coating (smooth side) on one side, as well as a protruding 'nose' on the top of the same side. This allows the tape to be affixed to 'cold' joint edges quickly, safely, and at exactly the right height, without the use of a gas burner.

TOK®-Band SK Mark can be applied without primer to properly prepared edges that are clean, dry and free of dust. The slightly profiled (way) side of the bitumen tape is the side without an adhesive coating. This side will later form the base for the 'hot' asphalt mix. If necessary, the optional primer **TOK®-SK Primer** can be used to boost the adhesion of **TOK®-Band SK Mark** to the joint edge.

Usage

TOK®-Band SK Mark is ideal for sealing joints in asphalt road construction. In accordance with ZTV Fug-StB, it is also used on components such as concrete curbs and gutters where hot mix is subsequently applied on top.

Thanks to its outstanding material properties, permanent and fully sealed joints are guaranteed.

Application

Weather conditions:

In accordance with ZTV Fug-StB, bitumen joint tapes may only be applied in dry weather and when the surface temperature of the asphalt is at least +5°C (+41°F). At temperatures between 0°C and +5°C (+30°F and +41°F), the product may only be applied if additional measures are taken (e.g. preheating of edges).

Requirements for connection edges:

In accordance with ZTV Fug-StB, the following basic requirements apply: Edge surfaces must be solid, even and straight for the successful application of bitumen joint tape. The connection edges must be bevelled, precision-milled or cut, or assembled using ready-made components. They must be free of dirt. Rust particles on steel components must be removed. Any residual dirt left adhering to the surface must be removed with a wire brush or compressed air. The edges must be dry.

Use of TOK®-Band SK Mark:

If all of the requirements for connection edges are fully satisfied, **TOK®-Band SK Mark** may be applied to the edge without primer. The relevant test results in accordance with TL/TP Fug-StB are available. If necessary, you can optimise the adhesion of the bitumen joint tape to the edge by applying **TOK®-SK Primer**.

In summer, the drying time of **TOK®-SK Primer** is just 3 to 5 minutes, depending on weather conditions, allowing further work to start quickly.

The profiled shape of **TOK®-Band SK Mark** makes it easier to achieve professional results with this joint tape. The tape is laid and almost 'hung' along the top of the edge. Thanks to the additional material it provides, the profiled 'nose' allows grain breakouts that develop on the edge tops after the rolling procedure to be sealed more effectively. The 'rivet head' is therefore constructed to be even more pronounced and robust. In connections that are not rolled, the conventional **TOK®-Band SK** should be used.

Application:

TOK®-Band SK Mark is applied to the prepared connection edge with the adhesive layer (smooth side) facing upwards.

The anti-adhesive paper should be removed just before the tape is laid. The adhesive surface (smooth side) of the laid **TOK®-Band SK Mark** is pressed onto the connection edge by hand or using a tool.

ZTV Fug-StB 15 – bitumen joint tapes:

In accordance with ZTV Fug-StB, bitumen joint tape must be laid with a 5-mm protrusion on rolled asphalt surface layers, so that a so-called 'rivet head' is produced when rolling the asphalt. This forms an additional seal on the surface and provides a clean 'closure'.

In cast asphalt surfaces, the joint tape is laid flush to the edge.

The width of the joint tape must be at least 10 mm.

In accordance with ZTV Fug-StB and TL Fug-StB, the quality of the material must be monitored by a third party and verified by placing an approval label on the packaging.

Typical Product Properties (Excerpt*)

Test	Unit	Typical results range	Requirement
Softening point (Ring&Ball method)	°C / °F	> +100 (+212)	> +90 (+194)
Cone penetration	0.1 mm	20 - 50	20 - 50
Recovery	%	10 - 30	10 - 30
Cold bending behaviour	°C / °F	≤ ±0 (+32)	≤ ±0 (+32)
Stretch and adhesive strength	% / N/mm ²	≥ 10 / ≤ 1,0	≥ 10 / ≤ 1,0

* For more product information as well as details on ordering and packaging, please refer to the product data sheet at denso-group.com.

TOK®-Band SK Drain

Self-adhesive bitumen joint tape for joints and connections in porous asphalt road surfaces.

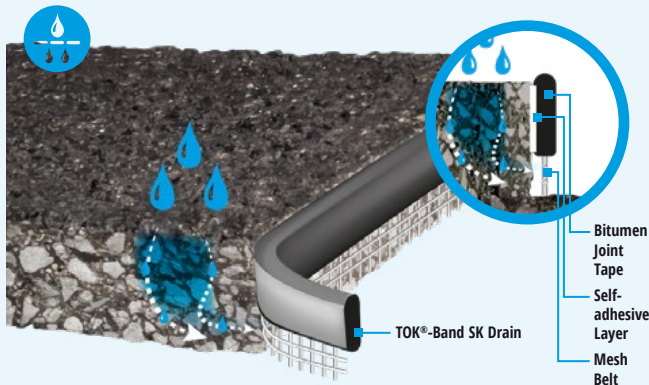

Cold processed – no burner required.



Water-permeable.



Fulfills all requirements of ZTV Fug-StB 15.



Processing temperature from +5°C to +50°C
(from +41°F to +122°F).

TOK®-Band SK Drain is a combination of our high-quality bitumen joint tape made from polymer-improved road bitumen with exceptional stretch and adhesion properties, and a water-permeable mesh tape.

TOK®-Band SK Drain has a homogeneous adhesive coating on one side of the bitumen tape body, allowing it to be affixed to 'cold' joint edges quickly and safely, without the use of a gas burner.

A heat-resistant mesh belt is incorporated into the bitumen tape body, which protrudes approximately 20 mm from the bottom edge of the tape.

TOK®-Band SK Drain and its associated primer, **TOK®-SK Primer**, have been tested in accordance with TL/TP Fug-StB and meet all the requirements of this regulation.

Usage

Das **TOK®-Band SK Drain** is used to form joints in porous asphalt road surfaces. Thanks to its excellent material properties and the special cross-section – the lower part of

which is water-permeable – a permanent and sealed connection is guaranteed. In addition, the mesh tape ensures that water drains away easily below the road surface.

Application

Weather conditions:

In accordance with ZTV Fug-StB, bitumen joint tapes may only be applied in dry weather and when the surface temperature of the asphalt is at least +5°C (+41°F).

At temperatures between 0°C and +5°C (+30°F and +41°F), the product may only be applied if additional measures are taken (e.g. preheating of edges).

Requirements for connection edges:

In accordance with ZTV Fug-StB, the following basic requirements apply: Edge surfaces must be solid, even and straight for the successful application of bitumen joint tape. The connection edges must be bevelled, precision-milled or cut, or assembled using ready-made components.

They must be free of dirt. Rust particles on steel components must be removed.

Any residual dirt left adhering to the surface must be removed with a wire brush or compressed air. The edges must be dry.

Use of TOK®-Band SK Drain:

If all of the requirements for connection edges are fully satisfied, the primer **TOK®-SK Primer** can be applied to the edge. Once the TOK®-SK Primer has dried, TOK®-Band SK Drain can be applied to the edge.

In summer, the drying time of **TOK®-SK Primer** is approximately 3–5 minutes, allowing further work to start quickly. Thanks to its special cross-sectional shape, **TOK®-Band SK Drain** has two distinct advantages when used in porous asphalt road surfaces:

Firstly, the product creates a professional sealed connection in the upper area, preventing grain breakouts and damage in the connection area.

Secondly, in the lower cross-sectional area (approximately 20 mm), the rain water can continue to drain.

This means that the original purpose and benefits of the porous asphalt coating are retained around the connection, particularly when conservation measures are needed on the surface.

Processing:

TOK®-Band SK Drain is applied to the prepared connection edge with the adhesive layer facing upwards.

The anti-adhesive paper should be removed just before the tape is laid.

Once the **TOK®-SK Primer** has been applied and is dry, the adhesive side of the laid **TOK®-Band SK Drain** is pressed onto the connection edge by hand or using a tool.

ZTV Fug-StB 15 – bitumen joint tapes:

In accordance with ZTV Fug-StB, bitumen joint tape must be laid with a 5-mm protrusion on rolled asphalt surface layers, so that a so-called 'rivet head' is produced when rolling the asphalt. This forms an additional seal on the surface and provides a clean 'closure'.

In cast asphalt surfaces, the joint tape is laid flush to the edge.

The width of the joint tape must be at least 10 mm.

In accordance with ZTV Fug-StB and TL Fug-StB, the quality of the material must be monitored by a third party and verified by placing an approval label on the packaging.

Typical Product Properties (Excerpt*)

Test	Unit	Typical results range	Requirement
Softening point (Ring&Ball method)	°C / °F	> +100 (+212)	> +90 (+194)
Cone penetration	0.1 mm	20 - 50	20 - 50
Recovery	%	10 - 30	10 - 30
Cold bending behaviour	°C / °F	≤ ±0 (+32)	≤ ±0 (+32)
Dilation and adhesive strength	% / N/mm ²	≥ 10 / ≤ 1,0	≥ 10 / ≤ 1,0

* For more product information as well as details on ordering and packaging, please refer to the product data sheet at denso-group.com.

TOK®-Band SK Drain – Application

The proven self-adhesive bitumen profile to seal joints / connections



The Edge

Preferably created using a precision router, so strong grain outbreaks are avoided and a professional edge is created for the joint tape!



Primer

Application of the **TOK®-SK Primer**.
Optimal application with a spray gun, for example. Drying time approx. 3–5 minutes, depending on the weather conditions.



Pre-lay

Pre-lay the roll in front of the machined edge.
Caution: Roll out the tape with the adhesive area upwards, so that contamination on the adhesive side is avoided!



Laying

Lay the tape.

Caution: Observe the tape protrusion of 5 mm! Press the tape firmly against the edge!



Laying

Professionally laid joint tape should be placed above the bituminous compound and below the water permeable mesh tape.



Compaction process

The first rolling process should be on the connection area 'new to old'.



Rivet head

The result of a professional installation is a much more pronounced protrusion, which forms a recognisable 'rivet head' on the surface.

The current German road construction law ZTV Asphalt-StB'

Creating sealed connections to installations.

In ZTV Asphalt-StB ('Additional technical terms of contract and guidelines for the construction of asphalt road surfaces') the topic of 'seams, connections' is covered in detail.

Section 3.3.3 (description of connections and joints):

"ZTV Fug-StB applies, unless stipulated otherwise. Connections of road layers made of rolled asphalt to cast asphalt or to installations should be **designed as joints**.

This does not apply to connections between asphalt road layers made of porous asphalt to installations. Connections should be **designed as joints** where the layers are of cast asphalt."

Section 1.2 (definitions, p. 11):

Connections are contact surfaces

- ▶ between different types of asphalt with different properties (e.g. rolled asphalt / cast asphalt)
- ▶ between asphalt layers or layers and installations (e.g. curbstones, pavement, or similar)



Installations in asphalt are often damaged because no joints are created.



TOK®-Band SK used on hydrant and valve caps and the adjoining asphalt surface.



Joint formation at curb gutters using **TOK®-Band SK** or applied with the **TOKOMAT®**.



TOK®-Band SK used on drainage channels in asphalt surfaces.

Remarks:

Paragraphs marked with a border line are 'Additional technical terms of contract', within the meaning of Art. 1 (2) 4. VOB part B – DIN 1961 of ZTV Asphalt-StB

is a part of the construction contract and must therefore be done in the way described.

In accordance with ZTV Asphalt-StB 07, joints on concrete parts, covers, gutters and manhole covers must be made when the asphalt is constructed up to them.

LONG-LASTING ROADS WITH TOK®-BAND

Typical damage without
using a bitumen joint tape



Expert working
with TOK®-Band



TOK®-Band SK DR

Bituminous tape with a triangular cross-section: ideal for forming fillets for bitumen waterproofing sheets at corner joints/upstands.

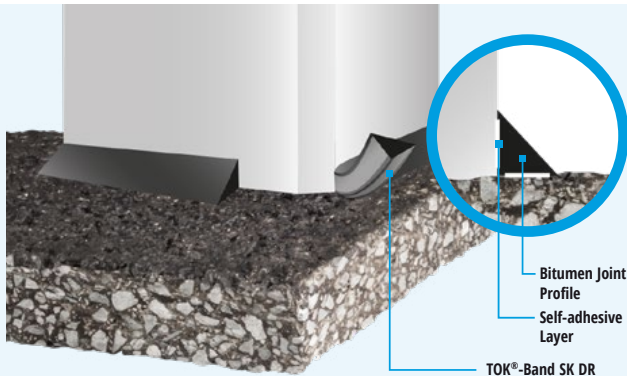

Tested in accordance with TL/TP Fug-StB.



Quick, economical installation.



Self-adhesive, no gas burner required for heating.

TOK®-Band SK DR is a high-quality bitumen joint tape made of polymer-improved road bitumen, which has excellent properties in terms of elasticity and adhesion.

TOK®-Band DR is available as a joint tape that is heated for application or is self-adhesive. **TOK®-Band SK DR** and its associated primer, **TOK®-SK Primer**, have been tested in accordance with TL/TP Fug-StB and meet these regulations in full.

Usage

TOK®-Band SK DR is used for sealing work in conjunction with poured asphalt or rolled asphalt. The triangular profile is also particularly suited for use as a wedge for bitumen

roofing and sealing sheets, e. g. for flashings and cappings of parking decks or on flat roofs. Due to its excellent material properties, permanent, tightly-sealed joints are guaranteed.

Application

Preparation of the connecting edges

According to the requirements of ZTV Fug-StB, the edges must be dry, clean and solid, and an undercoat of primer must have been applied. An undercoat or primer appropriate for the joint tape must be used. For **TOK®-SK Primer**, the undercoat **TOK®-SK Primer** (transparent) must be used. Air drying time in summer is about 3–5 minutes for the **TOK®-SK Primer**.

Installation of TOK®-Band SK DR

As soon as the primer coat has dried, the joint tape can be laid. Before application, the joint tape is laid out along the wall with the anti-adhesive paper upwards. The anti-adhesive paper should be removed just before it is laid.

The **self-adhesive TOK®-Band SK DR** does not have to be heated for application. It can simply be pressed onto the walls after the primer coat has dried.



Typical Product Properties (Excerpt*)

Test	Unit	Typical results range	Requirement
Softening point (ring and ball)	°C / °F	> +100 (+212)	> +90 (+194)
Cone penetration	0.1 mm	≈	20-50
Elastic recovery	%	10-30	10-30
Cold flexural behaviour	°C / °F	-9 (+15,8)	≤ ±0 (+32)
Adhesion and extensibility	% / N/mm ²	≥ 10 / ≤ 1,0	≥ 10 / ≤ 1,0

* For more product information as well as details on ordering and packaging, please refer to the product data sheet at denso-group.com.



TOK®-Band Spezial

Successful for
45 years.



TOK®-Band SK Mark

Self-adhesive & applied at
exactly the right height – thanks
to the protrusion profiling



TOK®-Band SK Drain

Self-adhesive & water-draining –
for even the most challenging
applications in road construction



MECHANICALLY EXTRUDED BITUMEN JOINT TAPE



24

TOK®-Riegel

On-site extruded bitumen joint tape, tested according to ZTV Fug-StB.



25





TOKOMAT®

The TOKOMAT® extrusion solution for mechanically extruded bitumen joint tape has impressed users across a wide range of countries in Europe for 25 years. Twice as fast as cutting and pouring: The TOKOMAT® seals 15 metres per minute.

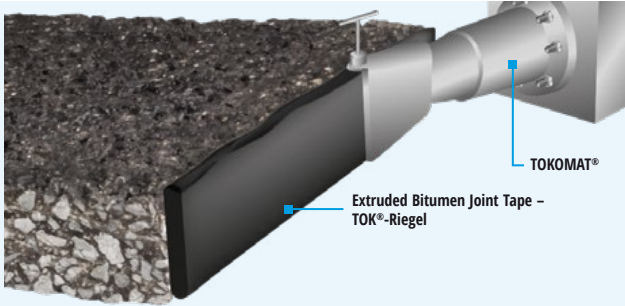
TOK®-Riegel

Bituminous compound that can be applied with TOKOMAT® for the creation and sealing of joints in asphalt road construction.



-  Quick and economical installation, particularly on long sections.
-  Optimum joint quality provided by mechanical processing with TOKOMAT®.
-  Filling out of breaks e.g. at milled edges.
-  Tested in accordance with ZTV Fug-StB.

TOK®-Riegel consists of a polymer-modified, binder-based compound. The specific composition of the raw materials and the high binder content ensure an effective and durable joint-connection.

TOK®-Riegel fulfils all of the requirements stipulated in the latest versions of the German laws ZTV Asphalt-StB and ZTV Fug-StB for compounds used to create joints and seams in asphalt road construction.

Usage

TOK®-Riegel is used to create joints in asphalt road construction. Joints are created when a connection is made between asphalt layers with different properties, or asphalt layers and other materials, e.g. installed components made of concrete or steel.

The material is worked in a heated, malleable state and fits optimally into any existing break even in rough surfaces.

Application

Preparation of the edge

Prepare the dry and clean joint surface with TOK®-SK Primer and leave to air dry. The coat of primer is always necessary. Only use the primer that we recommend, since the TOK®-Riegel compound and TOK®-SK Primer are part of the same system and have been tested as such, and have also been tested as part of external quality control testing.

Application of TOK®-Riegel

The material is heated in the TOKOMAT® to a temperature of approx. 80–100 °C (176–212 °F). The TOKOMAT® is applied to the joint surface, brought into position and configured for the application nozzle. The compound is then applied to the flange in the required dimensions. In areas containing breaks, etc. the speed should be adjusted so that the uneven walls can be completely filled out.

Typical Product Properties (Excerpt*)

- Tested as heat-treatable joint tape according to TL/TP Fug-StB.
- Tested as rail joint compound according to TL/TP Fug-StB.
- Tested according to the earlier TLbitFug 82.

Properties	Unit	Results	Requirements according to TL/TP Fug-StB (as a rail joint compound)
Processing temperature PT	°C / °F	~+80 (–+176)	1) Manufacturer's data
Density at -25 °C (+77 °F)	g/cm³	1.327	To be specified by manufacturer
Ring and ball softening point	°C / °F	+116 (+240,8)	≥ 85 / 185
Cone penetration	1/10 mm	50	≤ 50
Flow length	mm	0.5	Specify test value
Elastic recovery	%	12	10-60
Separation tendency	%	0.0	≤ 3 M-%
Falling ball test	-	passed 4 of 4	At -20 °C, 250 cm³, 3 of 4
Dimensional stability	mm	1.5	At 45 °C / 24h, ≤ 4.5
Volume change after thermal ageing	%	-0.37	Specify test value
Softening point after thermal ageing	°C / °F	+114 (+237.2)	Specify test value
Elastic recovery after thermal ageing	%	18	Specify test value
Elasticity and adhesive strength at -10 °C, 2 mm		Passed	Passed
without ageing Fmax	N/mm²	0.09	Specify test value
with ageing Fmax	N/mm²	0.10	Specify test value

* For more product information as well as details on ordering and packaging, please refer to the product data sheet at denso-group.com.

1) TOKOMAT® (temperature setting)
80 °C – 100 °C (+176 °F to +212 °F)

TOKOMAT®

TOKOMAT® – for the formation of joints at milled and cut flanges



- ✓ Practical and versatile.
- ✓ Quick and precise application of the bitumen joint tape.
- ✓ Average installation times of 10–15 m/minute.
- ✓ Also perfect for use in installations and concrete safety barriers, as per ZTV Asphalt-StB.

TOKOMAT®-System focuses in particular on such rough flanges to offer a practice-oriented solution that can really be viewed as ideal. With this extrusion tool, proven over decades of use, the polymer-modified bituminous compound **TOK®-Riegel** is applied on site to the suitably pre-treated dry flange at the correct profile and height. The suitability of this process has been shown by drill core analyses. The process fulfils all of the requirements of ZTV Fug-StB 01 regarding fusible bitumen joint tapes – even after over 5 years under heavy traffic.

TOK®-Riegel has been tested according to TL/TP Fug-StB 15 both as bitumen joint tape and rail joint pouring compound, and has met all of the requirements. The joint is applied directly to the flange at the correct location in one work step. Once asphalt construction is complete, the building site work is complete and no additional dirt is created by the subsequent cutting of joint spaces, for example.

Usage

An increase in the loads placed on road structures – especially due to the significant upsurge in HGV traffic – necessarily leads to increased maintenance work on our trunk roads and motorways. Renovation work on damaged traffic lanes has now become an indispensable form of modern construction work. The connection of the new road surfaces to the existing road surfaces is to be formed as a joint, in accordance with industry regulations (ZTV Asphalt-StB). Bitumen joint tapes can be used for this purpose.

Milling off the traffic lane creates a milled edge with a predominantly rough surface structure. Flanges of this kind are not especially suited to the typical techniques for joint creation:

- Cutting and filling with hot-poured compound
- Bitumen joint tapes

As practice shows us, this method is unsuited for properly meeting surface roughness requirements.



TOK®-Riegel

This joint compound is a bar form of the famous **TOK®-Band** – which has been well-known and in continuous development for decades. This soft, warm compound easily fills out even irregular rough surfaces directly on-site on the joint flange, ensuring the

creation of a secure and professional joint seal. The motor-driven **TOKOMAT®** is equipped with a storage shelf with which the **TOK®-Riegel** can be stored and fed to the machine while working.

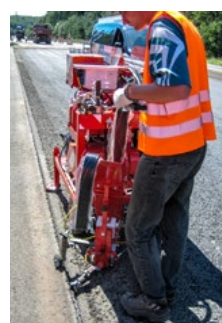
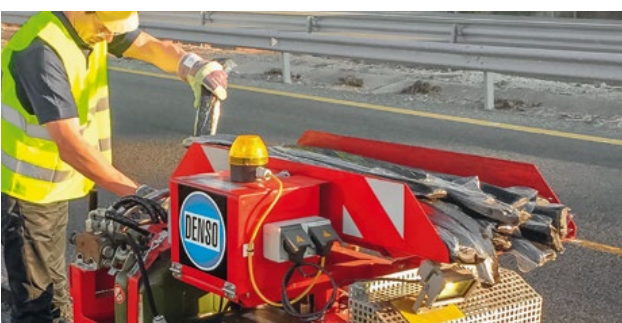

* For more product information as well as details on ordering and packaging, please refer to the product data sheet at denso-group.com.

TOKOMAT®-process in comparison to cutting & pouring



Cutting & pouring

Advantages

- + **Flexible in terms of timing** – not dependent on asphalt work.
- + **Cheap materials** (low-cost providers)

Disadvantages

- Often **requires a second period of closure to traffic.**
- Need to **remove cutting waste.**
- Exact path of joint **often not completely clear; impossible to cut precisely.**
- Risk of road surface being damaged soon after work as a result of improper cutting and pouring.



TOKOMAT®-process

Advantages

- + **Twice as fast.**
- + **One-step application.**
- + **Precise adjustment** along joint edge.
- + Better process for **A5.2 health and safety regulations.**
- + **Lane can be reopened immediately** – without closing to traffic again.
- + **No additional dirt.**
- + **Proven process.**

Disadvantages

- Joint tape should be applied **shortly before mixing**

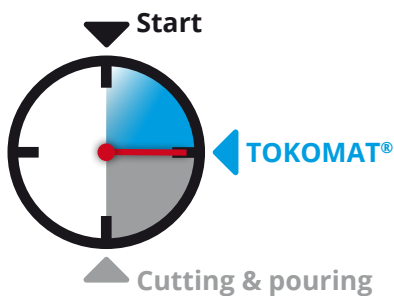

TOKOMAT®-process



Cutting & pouring



Maximum protection for workers and for joints

How do the A5.2 health and safety regulations affect joint loading?



The new A5.2 health and safety regulations for road construction sites came into force in December 2018. To protect workers, the **safety distance between them and the traffic** has been increased.

If the joint is being moved closer to the lane during road resurfacing, the constant flow of cars, heavy-goods vehicles and high temperatures will place significant stress on the joint material. In accordance with ZTV-Fug StB, during road resurfacing, a joint must be created and filled with approved joint material.

If a hot-poured compound is used, the new asphalt is applied first. Once the asphalt has cooled, a joint is cut between the new and the old asphalt cover layers.

Hot-poured joint compounds can stick to car tyres and – in the worst-case scenario – may be **pulled out of the joint** by a vehicle. If this happens, the repairs

are time-consuming and costly, and will create huge traffic delays.

If a joint is finished using the TOKOMAT®-process, this does not happen. The joint tape bonds permanently to the asphalt cover layer as soon as the new, hot asphalt is added.

As a result, the TOK®-Bitumen joint tape cannot be pulled out of the joint by car tyres.

The joints hold reliably over the long term in spite of road stress/strain.

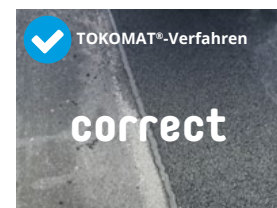



HOT POURING COMPOUNDS

hot processable

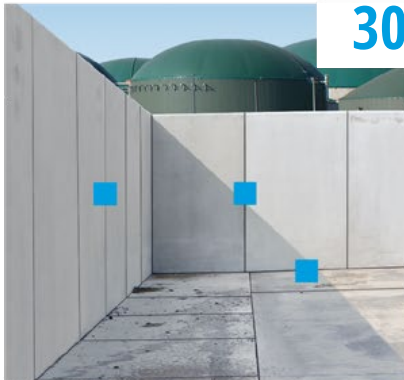

TOK®-Sil Resist

Hot-processable, stable bituminous compound for horizontal and vertical joints for use in JGS (manure/ slurry/ silage effluent) plants.



TOK®-Melt N1

Hot-processable, bituminous pouring compound for joints in concrete and asphalt, Type N1 (elastic).

TOK®-Sil Resist

Bituminous, acid-resistant and low-carbonate joint compound for horizontal and vertical applications.

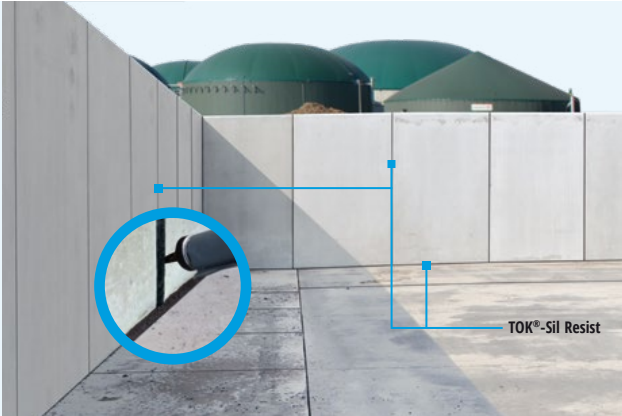

- ✓ Stable – suitable as a system solution for horizontal and vertical joints.
- ✓ Bitumen-based and low-carbonate.
- ✓ Long-term stability against silage effluent and slurry/liquid manure.
- ✓ Excellent recovery capacity.
- ✓ Suitable for new construction and for maintenance – can bear loads immediately after installation and cooling.

TOK®-Sil Resist is a one-component, hot-workable bitumen-based joint sealant. This compound has exceptional properties, due to its special formulation, which includes bitumen, polymer components and other innovative substances.

Usage

TOK®-Sil Resist is used predominantly in applications that require a high level of chemical resistance. This is the case in plants that work with liquid manure, slurry and silage effluent.

Application

General instructions

As a rule, the joint compound should only be installed in dry conditions and where joint surface temperatures are at least 0 °C (+32 °F). In conditions outside the temperature range given, special precautions may have to be taken.

Preparing the joints

Contact surfaces can be concrete or asphalt. The contact surfaces must be dry, clean, and free of loose detritus and release agents. Concrete must be at least 7 days old and attained at least 70% of its 28-day compressive strength at the time of jointing. Coated surfaces may have to be pre-treated accordingly (e.g. by increasing the joint gap width or by abrasion). Joint dimensions must follow the guidelines outlined by the general technical approval for both floor and rising wall joints, and run plane-parallel. Joint width for traversable joints is up to 15 mm according to the approval. The recommended joint depth for concrete joints is at least twice the joint gap width and is also dependent on expected changes in the joint gap width. When working with concrete sealing layer joints, ensure that neither the underlay material nor the joint sealant in the joint space can be crushed downwards, and that contact with vehicle tyres on the road above is avoided (chamfer formation at the concrete joint edges). Appropriate precautions may need to be taken against pressure loading on the joints. Asphalt sealing layer joints must generally be filled over the entire surface-layer height. Joints have to be cut according to the approval and must not be separated. In all cases, "three-surface adhesion", i.e. bonding of the joint sealant to the subsurface (and not to the joint flanges!) must be avoided. This requires the use of an approved heat-resistant lining (e.g. lining strip or silicone paper). Details about measuring joint cross-sections and about suitable linings can be obtained by consulting the latest **ZTV Fug-StB**. After correct wall pre-treatment, the contact surfaces are primed across their whole area with **TOK®-Sil Primer**.

In particular, **TOK®-Sil Resist** stands out because of its excellent acid resistance – particularly against fermentation acids – and because of its universal applicability to horizontal and vertical joints.

In these plants, long-term material resistance to slurry/liquid manure and silage effluent is imperative. **TOK®-Sil Resist** can be used on concrete and asphalt contact surfaces, and has excellent elasticity and adhesive properties.

Air drying time is approx. 3-5 minutes at +23 °C (+73.4 °F). After the primer has air-dried, the lining strip is inserted into the joint.

Application on vertical joints

Here, **TOK®-Sil Resist** is applied using a special machine (**SEALOMAT®**). The material bars are filled into aluminum cartridges using a special extrusion tool. Immediately after filling, the material is inserted into the vertical joint area. The material must be applied immediately after filling into the extrusion tool to ensure that the heated compound can be easily pressed out of the gun. Compound that has cooled too much inside the extrusion tool can no longer be pressed out. Once the material has been completely pressed out of the extrusion tool, it can easily be refilled with new material and used immediately.

Horizontal application

TOK®-Sil Resist can also be easily installed into horizontal joints using the extrusion tool. For larger quantities, a special extrusion tool can also be used for working with the compound.

Benefits of TOK®-Sil Resist

In addition to the above-mentioned advantages of the compound as a system solution, **TOK®-Sil Resist** also has the important advantage that the compound, once applied, can be very easily repaired if it suffers damage for any reason. In this case, the damaged area is first carefully melted, e.g. with a hot air dryer. Old material must be removed. The new compound can then be applied to this prepared area and, if necessary, trowelled smooth using e.g. a hot jointing iron. Necessary repairs can therefore be carried out quickly and easily. Please ensure compatibility with coating materials, e.g. silo varnish. The temperature of the storage substrates must not exceed +30°C (+86°F) when in contact with the joint sealing system. During the ensiling process, the joint sealing system may be exposed to temperatures of +40°C (+104°F) for a short time.

Typical Product Properties (Excerpt*)

Technical data	Value	Unit
Density	1.131 (approx.) (at +21 °C/+69.8 °F)	kg/l
Softening point (ring and ball)	> +85 / +185	°C / °F
Elastic recovery	40 (approx.) (at +21 °C/+69.8 °F)	%

* For more product information as well as details on ordering and packaging, please refer to the product data sheet at denso-group.com.

TOK®-Melt N1

TOK®-MELT N1 is an elastic hot-poured compound based on polymer-modified bitumen.

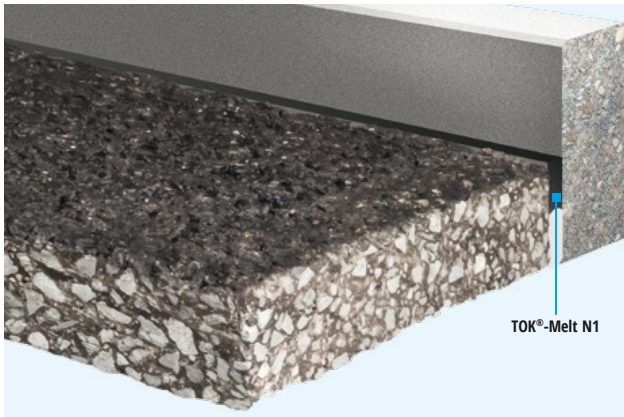

Fulfils the requirements of **DIN EN 14188-1, type N1.**



Fulfils the requirements of the current TL/TP Fug-StB (elastic).



Excellent plasto-elastic properties.



Type N1 joint compounds can be used for changes in the joint gap width of up to 35%.

TOK®-Melt N1 is a joint sealing compound used to seal horizontal and slightly inclined joints in concrete and bituminous road surfaces experiencing light to virtually non-existent traffic.

The sealing compound is particularly suitable for joints in bridge construction between the bridge cap and the road surface.

Application

All work must be carried out in accordance with the current **ZTV Fug-StB**.

Sealing depth

For hot-poured compounds, the sealing depth should be 1.5 x the joint width or 12 mm, whichever is the greater.

Preconditions

The target road surface for filling and sealing work must be closed to traffic while the work is being carried out. All work must be carried out in dry weather and when the structural component has a surface temperature of over +5 °C (+41 °F). At temperatures between +2 and +5 °C (35.6 and +41 °F), work can be continued if appropriate additional precautions have been taken. The subsurface must be dry. Concrete must be at least 14 days old.

The joint flanges must be dust-free and must not contain any substances capable of acting as release agents.

Preparation of the joint gap

If the joint is already filled, this must be removed down to the planned pouring depth without damaging the joint flanges. Old sealing compound residue does not normally impair the durability of the new compound, assuming the substances are not incompatible. A brushing machine or similar tool should be used for cleaning. Pressure-driven hot air blowers should be used if artificial drying or pre-warming of the fill area is necessary.

Installation of the liner/Primer

The liner substance must be installed (without causing damage) at the depth necessary for the planned pouring depth. **TOK®-S Primer** is applied with a brush or spray equipment and must be applied to form a film that completely covers the flanges of the fill area. Excess liquid must not be permitted to collect on the liner substance. Accordingly, the undercoat should be applied first and the lining installed only once the undercoat has air-dried. The primer must be completely dry before applying the jointing compound. The drying time

depends on ambient conditions and ranges from 30 minutes to a value several times larger. In the event of a long waiting time before applying the primer and the compound, the joints may require careful cleaning again. The use of **TOK®-S Primer** is generally recommended.

Heating

The sealing compound must be melted in a double-walled heating kettle fitted with a stirrer, cover and an indirect heating element. The heating process must be carried out slowly (= carefully), with the first filling reaching approximately 1/3 of the total volume. Following this, more material can be added to the liquid compound.

The melting temperature must be maintained while stirring continuously. In so doing, ensure that the prescribed pouring/working temperature is not exceeded anywhere in the compound, as separation and/or disintegration of the sealing compound can otherwise occur. This can render the material unusable, meaning it may lose the properties it requires to function properly. If the compound cannot be worked on the same day, the kettle should be emptied completely. Once cooled, **TOK®-Melt N1** compound can be re-melted no more than twice.

Joint filling

Machines for hot pouring should be equipped with a feed pump. Normally, the joint fill area is filled mechanically in a single step. Depending on the filling cross-section, it is also possible to pour in two steps – although the surface of the first layer must not be soiled. Manual pouring is possible in exceptional cases if the structural components are difficult to access or if the work involves small jobs in the overall project.

Joints must be filled without air pockets. Projections must be scuffed off, taking care not to impair the bonding to the joint flanges. Excess material should be removed before the material hardens.

Typical Product Properties (Excerpt*)

Test	Unit
Type	Plasto-elastic hot-poured compound
Base	Polymer-modified bitumen
Density	1.15 g/cm ³ (approx.)
Pouring temperature	+160 to 180 °C (+320 to 356 °F) (approx.) – DO NOT overheat!
Colour	Black
Usage	1.15 kg (approx.) per litre of fill area
Primer on bitumen/concrete	TOK®-S Primer

* For more product information as well as details on ordering and packaging, please refer to the product data sheet at denso-group.com.



COLD POURING COMPOUNDS

cold processable

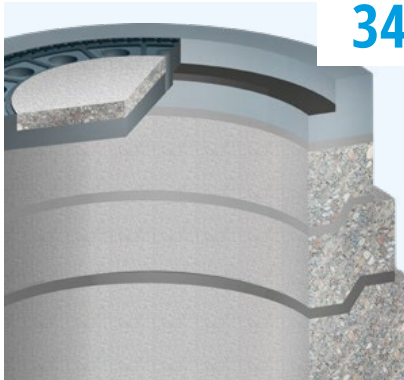
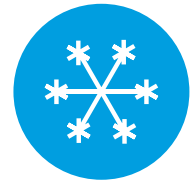

34

DENSOLASTIC®-KU

Hand-processable, permanently elastic, **vibration and noise dampening pouring compound** for manhole covers and similar areas.



36

DENSOLASTIC®-SV

Two-component polyurethane-based **cold pouring compound for sensor or induction loop insertion** into concrete or asphalt road surfaces.

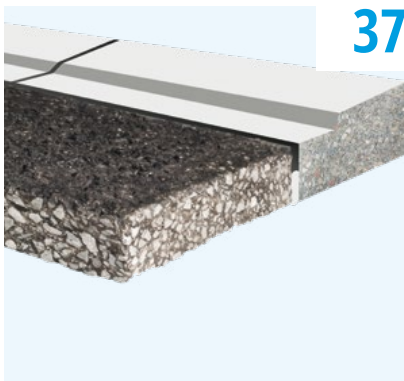

37





DENSOLASTIC®-VT

Two-component, **fuel resistant cold pouring compounds** for joints in surfaces in accordance with the German Water Resources Law (WHG).

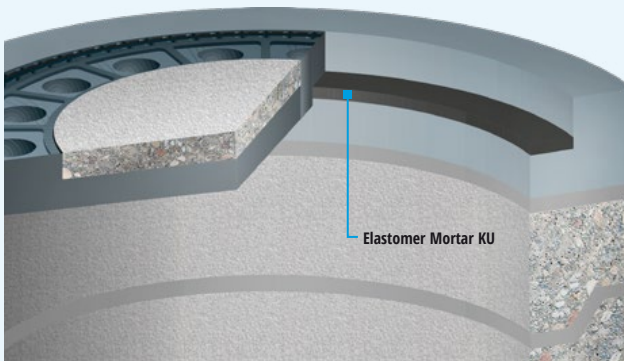
DENSOLASTIC®-KU

A manually applied, permanently elastic, vibration and noise dampening embedding compound for manhole covers and similar applications.



-  Permanently elastic.
-  Can be worked quickly and easily.
-  Reduces noise.
-  Traffic flow restored quickly.

DENSOLASTIC®-KU consists of a pourable, two-component polyurethane-based system that cures into an elastic material.

The filling compound has short-term resistance to diesel fuel, and is also frost- and road salt-resistant.

Usage

DENSOLASTIC®-KU is used as an elastic and vibration-dampening embedding compound for road manhole covers, where it has a noise-reducing effects.

Application

Preparing the subsurface

Sand, dust, oil, petrol and other loose particles must be removed from the surface.

- Clean the support rim to remove heavy soiling.
- As a final step, dry the cleaned area using a gas torch, for example.
- Remove any rust from the surface of the support rim with a steel brush and then wipe dry.
- Prime the support area and inner rim with **DENSOLASTIC®-E Primer** and leave to air dry (approx. 5-10 minutes).
- On the inside rim of the cover support, apply **TOK®-Band SK** 25 x 8 mm with approximately 3-4 mm protrusion.

Mixing the material

- Mixing ratio
A : B = 100 : 24 (weight),
A : B = 100 : 13 (volume).
- Stir component A well before working, then add component B.

- Now mix both components together well (approx. 60 seconds) using the stirrer provided. The material's pot life is about 4 minutes at +23 °C (+73.4 °F); the material is load-bearing after 24 hours. The pot life will be shorter for higher temperatures.

Product application

- After mixing, the compound is distributed evenly onto the support rim.
- Depending on the weather and the temperature, wait approx. 10 to 20 min. until the compound has dried but has not yet cured (finger test).
- We recommend sprinkling the surface with talcum powder to help prevent the cover from sticking to the manhole ring. Lay the manhole cover into position and drive over to press into place. Take care to ensure the correct timing between applying the compound and placing the cover to achieve the desired effect.
- For subsequent maintenance work, the street surface and cover should be marked (e.g. with chalk) before removing the manhole cover, so as to ensure a perfect fit when replacing the cover.

Typical Product Properties (Excerpt*)

DENSOLASTIC®-KU is a two-component, polyurethane synthetic that cures into an elastic material. The material is characterized by the following properties:

- Vibration-reducing
- Chemically and mechanically resistant
- Permanently elastic

- Long-term resistance at temperatures from -20 °C to +70 °C (+68 °F to +158 °F)
- Resistant to water, saline solution (10%), sodium hydroxide solution (5%) and engine oil (SAE 10 W 40)

Pot life	4 min. (approx.)	
Density (cured)	0.73 kg/l (approx.)	
Shore hardness A	65 ± 5	DIN 53 505
Tensile strength	3.5 N/mm ² (approx.)	DIN 53 455
Elongation after fracture	200% (approx.)	DIN 53 544
Rebound elasticity	40% (approx.)	DIN 53 512

* For more product information as well as details on ordering and packaging, please refer to the product data sheet at denso-group.com.

DENSOLASTIC®-KU – Application

Eliminate rattling noises quickly and easily



Cleaning

After opening the manhole cover, clean the supporting edge of any gross contamination.



Drying

Finally, dry the area using a gas flame.



Remove any rust from the surface of the supporting edge with a steel brush and then wipe dry.



Apply the primer

Pre-coat the support area and inside edge with **DENSOLASTIC®-E Primer** and let it dry (approx. 5–10 min).



Install the formwork

On the inside edge of the cover support, apply **TOK®-Band SK** 25 x 8 mm with approximately 3-4 mm protrusion.



Mixing

Stir component A well before processing, then add component B.



Stirring

Mix the two components with the supplied rod (approx. 60 seconds). Pot life of the material at +23 °C (+73.4 °F): approx. 4 min. The pot life reduces with increased temperatures.

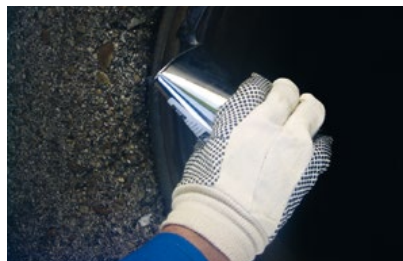

Pour out

After mixing, the compound is evenly distributed on the support edge.



Allow to dry

Depending on the weather and the temperature, wait approx. 10 to 20 min. until the compound has dried but has not yet cured (finger test!).



Sprinkle with talcum powder

It is recommended to sprinkle the surface with talcum powder to help prevent the cover from sticking to the manhole ring.



Put the cover back on.

Then replace the manhole cover. Pay attention here to the correct timing between applying the compound and placing the cover to achieve the desired effect.

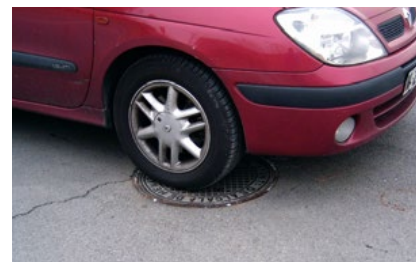

Driving over

The cover is pressed in by driving over it.

DENSOLASTIC®-SV

Two-component, polyurethane-based, cold-poured compound for bedding sensor or induction loops into concrete or asphalt road surfaces.

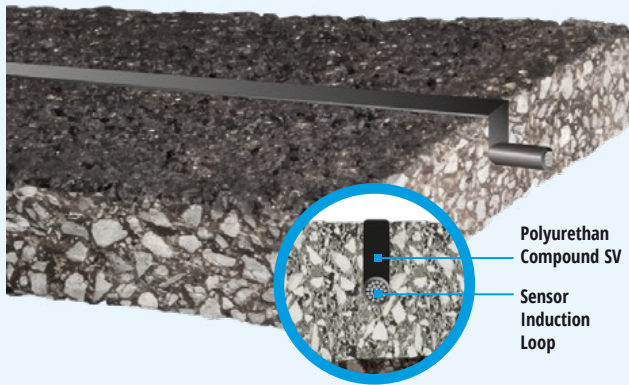

- ✓ Optimum working viscosity.
- ✓ Homogeneous; can be sanded.
- ⌚ Traffic flow restored quickly after 1–2 hrs, depending on weather.
- ✓ Very good pressure transfer.
- ✓ High degree of mechanical resistance.

DENSOLASTIC®-SV is a two-component polyurethane resin compound with a high final hardness (Shore hardness D, approx. 75). The colour of the compound is black. The material consistency is designed to enable homogeneous application without cavities. One use of **DENSOLASTIC®-SV** is to fill slits in asphalt or concrete surfaces. Embedded in the sealing compound in the slits are (piezoelectric) sensors that are incorporated into the

road surface for speed measurements (for example). **DENSOLASTIC®-SV** can be used both for repairs to existing measuring sites and for the creation of new measuring locations. Prior use of the primer **DENSOLASTIC®-SV Primer** ensures perfect adhesion to the contact surfaces.

Application

Preparations before application

The cross-section of the incisions (slits) used to lay sensor systems is normally 18/25 mm (W/D). The incisions must run parallel to each other. The walls of the incisions must be clean-cut.

Preparation of the walls

The walls must be clean and dry. Ideally, the incisions should be blown out using compressed air in order to remove any dust. Before applying the primer, the edges of the walls should be masked using masking tape or similar product to prevent soiling. Once matched to the system (see separate product information), the **DENSOLASTIC®-SV** After the primer is prepared in the manner previously described, it is applied to the walls, ensuring full coverage. **DENSOLASTIC®-SV Primer** is used on bituminous walls, semi-rigid surfaces, concrete walls and metal walls. On metal walls (particularly stainless steel), special pre-treatment may be necessary. Any existing corrosion protection layer, etc. must be removed. Very smooth surfaces may have to be roughened with sandpaper, for example. After air drying the primer (approx. 15–30 min.), the sealing compound can be applied.

Working the compound

Components A and B are mixed together with a special tool (e.g. drill with mixing blade Collomix WK 70) for 1–2 min. at a rotation speed of max. 500 rpm (in order to mix in as little air as possible). Ideally, component A will be stirred first beforehand. Afterwards, the mixed material is poured immediately.

The surface temperature of the slit walls must be between +5 °C (+41 °F) and +40 °C (+104 °F). Always take care to observe the dew point. Any rising air bubbles must be removed (e.g. by painting over with a brush or by briefly scorching with a gas burner) before the sealant solidifies. The masking tape applied before primer application must be removed directly after pouring. The solid compound can be sanded off after approx. 60 minutes following application (at approx. 23 °C/+73.4 °F). After approx. 24 hours (at approx. +23 °C/+73.4 °F), the compound is tack-free and completely hardened. The pot life and the hardening time are temperature-dependent and decrease with rising temperatures. Until hardened, ensure the material is well-protected from moisture.

Cleaning tools

Tools and working equipment can be cleaned using acetone. Already-hardened material can be removed mechanically.

Typical Product Properties (Excerpt*)

Technical data	Unit	Value
Density (A+B, hardened)	kg/l	1.45 (approx.)
Colour	-	Black (anthracite), silver-grey available upon request
Mixing ratio (A:B)	-	4:1 (parts by weight)
Pot life	Minutes	5–8
Curing time	Hours	24 (approx.)
Can bear traffic afterwards	Minutes	60 (approx.)
Can be sanded after application	Minutes	60 (approx.)
Shore D (when set hard)	-	75 ±5
Water absorption (5 d at +23 °C/+73.4 °F and 5 d at +40 °C/+104 °F)	%	< 2.0% weight increase (by weight)
Max. temperature after mixing (150 g of compound)	°C / °F	+65 (+149)

* For more product information as well as details on ordering and packaging, please refer to the product data sheet at denso-group.com.

DENSOLASTIC®-VT

Two-component, fuel-resistant pouring compound for joints in asphalt and concrete surfaces in storage plants.

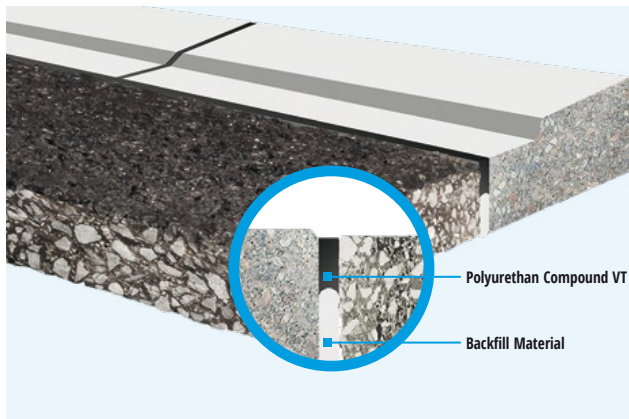

- ✓ Approval for LAU and HBV plants (contact surfaces: concrete, asphalt, semi-rigid surface courses and stainless steel).
- ✓ One coat of primer for all contact surfaces.
- ✓ Usability officially proven regarding asphalt surfaces for vehicle use.

DENSOLASTIC®-VT joint sealing system consists of a two-component, polyurethane-based material. The two components (A + B) are mixed at the construction site according to the defined mixing ratio and then poured into the joint either directly from the bucket or by using a special dispenser gun. The primer system **DENSOLASTIC®-VT Primer** must also be used for such applications. The sealing compound hardens elastically and is self-levelling.

Usage

One particular use of **DENSOLASTIC®-VT** is for joints in surfaces that must be sealed in a generally media-resistant way according to the German Water Resources Act (WHG) or

Application

The instructions and regulations stipulated in approval guidelines must always be observed. Application must be carried out by a professional firm as defined by the WHG.

Joint dimensions

The dimensions and distances between the joints must be specified in accordance with the expected load and the contact surfaces. On traffic-bearing surfaces, the joints must normally not be filled up to the upper edge to avoid tyre contact etc., which would cause undue strain. Concrete walls must always have an edge break (chamfer) in accordance with the guideline annex. In these areas, the joint filling height should end approx. 3–6 mm under the joint upper edge. The width is normally between 8 mm and 20 mm, and the height of the joint filling at the contact surfaces of concrete, steel and semi-rigid coatings is between 6 mm and 12 mm. On these contact surfaces, the height of the joint filling must always be approx. 0.8-1.0 times the joint width.

Important note:

The applicability of joint sealants in traffic-bearing asphalt surfaces regulated by the WHG must be generally proven. The applicability of DENSOLASTIC® VT has been proven. This means:

In these areas, the joint sealing system must be installed over the entire wearing course height. Example: In a 4 cm-thick asphalt sealing layer, the joints must be cut 4 cm deep and must be poured 4 cm deep. The primer (**DENSOLASTIC®-VT Primer**) must generally be applied as usual, but over the entire depth of the joint walls. A separating layer (e.g. silicon paper) or lining must be laid on the joint bottom, so that the sealant adheres only to the walls and not to the joint bottom. For joints that have frequent contact with process fluids (e.g. at petrol stations), special working guidelines according to the DIBt approval regulations must be observed. In general, joints in such areas must be treated as maintenance joints according to DIN 52 460 and regularly inspected.

In accordance with DIBt approval guidelines, the joint sealing system is resistant to petrol fuel, aircraft fuel, heating oil, diesel, unused motor and gear oils, mineral acids up to 20%, inorganic lyes, aqueous solutions of inorganic salts, biodiesel and AdBlue (35% urea solution in catalytic converters).

other laws and regulations. **DENSOLASTIC®-VT** is suitable for use in asphalt surfaces, concrete surfaces and surfaces consisting of semi-rigid surface courses.

Preparation of the joints (joint walls)

The best contact with the joint filling and/or primer system is ensured by cut walls. The joint space must be clean and dry. A lining (e.g. polyethylene or foam, not sand or chippings) must be placed into the joint to prohibit 'three-side adhesion'. The lining must not be water-absorbent or outgassing (water absorption ≤ 3%).

Always ensure that the primer(s) stipulated by the manufacturer is/are applied to the walls along the entire area. For bituminous walls, semi-rigid surface courses, concrete walls and metal walls such as stainless steel, **DENSOLASTIC®-VT Primer grey and black** is used.

On metal walls (particularly stainless steel), special pre-treatment may be necessary. Any existing corrosion protection layer, etc. must be removed. Very smooth surfaces may have to be roughened with sandpaper, for example, with sandpaper. Good results have been observed with a 36 grit paper.

Processing the sealant

Before mixing, the joint wall edges should be covered with e.g. crepe masking tape in order to avoid soiling. The masking tape should be removed again before the material starts to harden. Components A and B are mixed together with a special tool (e.g. drill with mixing blade Collomix WK 70) for 4 minutes at a rotation speed of max. 500 rpm (in order to mix in as little air as possible). The surface temperature of the joint must be between +5 °C (+41 °F) and +40 °C (+104 °F). The temperature must be ≥ 3 °C/+37.4 °F above the dew point. Any rising air bubbles must be removed (e.g. by painting over with a brush) before the sealant solidifies. The joint compound is tack-free and fully hardened after 24 hours. The pot life and the hardening time are temperature-dependent and decrease with rising temperatures. The material must be protected from moisture until it has hardened. During application, records must be kept of the working conditions, particularly in the case of environmental protection measures. Before installation, the state of the walls, etc. must be inspected. After installation, wall adhesion in particular must be regularly inspected.

Cleaning tools

Tools and working equipment can be cleaned using acetone. After hardening, the material will only be removable mechanically.

Typical Product Properties (Excerpt*)

Technical data	Unit	Value
Density (A+B, hardened)	g/cm ³	1.6 (approx.)
Mixing ratio (A:B)	-	4:1 (parts by weight)
Pot life	Minutes	15 (approx., weather-dependent)
Permissible total deformation on hardening	%	25 (in relation to joint width)
Curing time	hrs.	24–48 (weather-dependent)

* For more product information as well as details on ordering and packaging, please refer to the product data sheet at denso-group.com.



JOINT SEAM ADHESIVE

for seams in asphalt road surfaces



TOK®-Plast

Bituminous compound for seams in asphalt road surfaces.

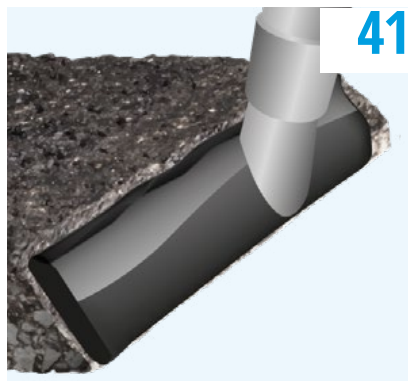

PLASTOMAT®

Application system for TOK®-Plast.

TOK®-Plast

Cold-worked bituminous compound for seams in asphalt road surfaces.

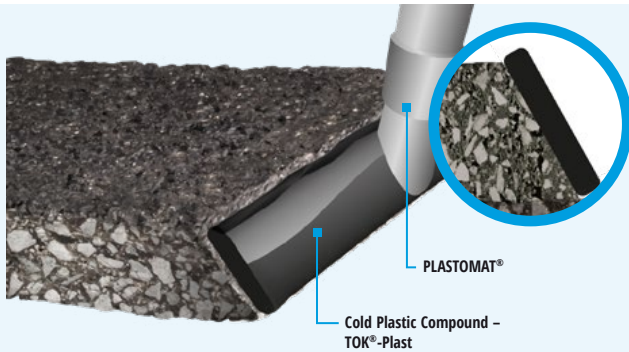

Can be applied without a primer.



For cold-worked applications.



High level of wet stability.

TOK®-Plast is a solvent-based, synthetic fibre-reinforced compound based on a polymer-improved road construction bitumen. Suitable fillers result in a viscous consistency to ensure excellent 'wet stability' at the flange immediately following application.

The **TOK®-Plast** compound complies with the regulations for joining bituminous surface joint seams to one other (see also ZTV Asphalt-StB).

Usage

Seams form in asphalt road surfaces when installing asphalt mixtures with similar properties in lanes (longitudinal seams) and as a result of longer work breaks (lateral seams). The appropriately prepared seam surface is coated with **TOK®-Plast** in the required application quantity according to ZTV Asphalt-StB.

For longitudinal seams, this process is most commonly carried out mechanically using **PLASTOMAT®**. For lateral seams and similar types of smaller-scale applications – which may also involve other asphalt layers – application is carried out using a brush. Due to its good adhesive qualities, **TOK®-Plast** ensures a highly durable seam quality.

Application

TOK®-Plast is processed cold.

- Mechanically using the **PLASTOMAT® Standard** or **PLASTOMAT® Mini**.
- Manually using a brush or spatula.
- The seam surface is prepared by chamfering or using an edge roller, and then it is properly compacted. It is then coated with **TOK®-Plast**.
- An undercoat of primer is not required.
- The seam surface must be dry and clean.
- Due to its high wet stability, the material does not flow away from the wall.
- The installation of the asphalt mixture is usually not time dependent after the application of **TOK®-Plast**, but it should take place on the same day when possible.
- Once the installed material has been applied, it must not be subjected to vehicle traffic.

Caution:

After application, the compound must air-dry, because it contains solvents. Air drying time is approx. 20–30 minutes (depends on weather). During this air-drying time, the fresh compound must not come into contact with a naked flame or other source of ignition.

When installing the asphalt, and for the application of the seam adhesive, observe the regulations of the latest ZTV Asphalt-StB!



Typical Product Properties (Excerpt*)

Test	Unit
Binder	Polymer-modified bitumen
Density	1.0 g/cm ³ (approx.)
Solvent	Special gasoline
Flash point	-18 °C (-0.4 °F) DIN 51755
Hazard class	A 1
Mass fraction of soluble binder	40–60%
Mass fraction of fillers	< 20%
Softening point of the solid	> +120 °C (+248 °F)
Wet stability at:	
+3 °C (+37.4 °F)	stable
+50 °C (+122 °F)	stable

* For more product information as well as details on ordering and packaging, please refer to the product data sheet at denso-group.com.

PLASTOMAT®

PLASTOMAT® – for seam formation in bituminous road construction



- ✓ Practical and versatile.
- ⌚ Quick and precise application of the TOK®-Plast seam adhesive.
- ✓ Ideal for construction work of any size.

Seams in wearing courses are caused by the lane-by-lane laying of a bituminous mixture with similar properties. Sealed seams in bituminous road surfaces is essential to ensure a long surface life, road traffic safety and driving comfort.

Seam production with **TOK®-Plast** meets the requirements of the latest German 'ZTV Asphalt-StB' regulations. **TOK®-Plast** offers a number of outstanding properties, including excellent 'wet stability' at the wall directly following application by the **PLASTOMAT®** tool.

Praxisorientierte Lösungen

The **PLASTOMAT®** models offer a range of equipment for working with the **TOK®-Plast** seam adhesive in road construction. The self-propelled **PLASTOMAT®** is fitted with a 4-stroke petrol engine and a combined gear/volute pump. This design means an even, adjustable and autonomous propulsion is guaranteed.

As a result, a high level of performance with a uniform layer thickness is achieved while ensuring that handling is simple and straightforward for the equipment. Thanks to the fibre-reinforced, polymer-improved composition of the **TOK®-Plast** compound, a very high level of 'wet stability' is achieved after cold application without additional heating being required.

TOK®-Plast is supplied by a pump and fed to the distribution nozzle via a hose line. This ensures the coating of the seam wall at the correct height. **PLASTOMAT®** has been specially designed for the **TOK®-Plast** compound and for everyday use on a construction site. Make the most of its benefits!

We strongly advise against the use of other cold compounds available on the market with the **PLASTOMAT®**. If they are used, we are unable to accept any warranty claims for damage to the equipment or substandard construction work.

PLASTOMAT® Models

PLASTOMAT® Standard:

Perfect for any type of construction site. Weight 100 kg (approx.), incl. accessories, excl. compound.



PLASTOMAT® Mini:

Ideal for smaller-scale building work. Weight 75 kg (approx.), incl. accessories, excl. compound.



TOK®-Plast

TOK®-Plast is a solvent-based, synthetic fibre-reinforced compound based on a polymer-improved road construction bitumen. Suitable fillers result in a viscous consistency, to ensure excellent 'wet stability' at the wall immediately following application.

The **TOK®-Plast** compound complies with regulations for joining bituminous surface seams to one other (see also 'ZTV Asphalt-StB').

* For more product information as well as details on ordering and packaging, please refer to the product data sheet at denso-group.com.

Sealing seams in asphalt surfaces

Sealing seams in asphalt surfaces is an often underestimated and important work step. If this is not properly done, or if unsuitable materials are used, it can lead to avoidable and costly damage. The treatment of seams is described in detail in the applicable directives, exact definitions can be found in ZTV Asphalt-StB and ZTV Fug-StB.

Here, a distinction is made between 'seams' and 'connections'. Seams are formed at the connection between asphalt layers with similar properties. Longitudinal seams, for example, caused by the mechanical installation of lanes in the "fresh on fresh" procedure. Connections are formed at the connection of asphalt layers with different properties, e.g. when installing new mix onto an old blacktop surface in machined areas.

There are two variants specified in the regulations for the creation of seams:

- **Hot process:** where hot-processed materials are injected.
- **Coating** with cold-processed compounds.

A bitumen B 160/220, for example, is sprayed on the edges. A 'cold' variant is the use of bituminous materials, such as **TOK®-Plast**, which is applied mechanically using a **PLASTOMAT®** or by hand in a prescribed thickness on the seam edge. **TOK®-Plast** fulfils the requirements of the regulations, and the results have been documented in a test certificate issued by the Landesgewerbeanstalt Bayern (the Bavarian state testing authority / LGA).

The installation of cold processed plastic compounds offers very significant advantages:

- No large equipment, such as cookers, or similar, is needed.
- Especially when processing mechanically using the **PLASTOMAT®**, the plastic compound is laid at a prescribed thickness and over the entire surface of the whole seam edge. The **PLASTOMAT®** device can also be quickly adjusted for various layer thicknesses and different edge heights.
- The plastic compound is stable and can be applied after a slight delay following the installation of the mixture.

When spraying the joint edge with hot processed compounds, it cannot be guaranteed that the compound will be distributed evenly. In addition, the mixture is not stable, so it can run off the edge and form a puddle on the underlay. At this point there can be an over-enrichment of the bituminous binder or bearer layer.



JOINT SEAM ADHESIVE

Durable roads mean everything.

100 years of innovation strength for maintenance our transport routes.
Protecting people and nature. denso-group.com

100 Years of DENSO. Advanced in Sealing.





MORTARS, COMPOUNDS, PROFILES AND REINFORCEMENT

for maintenance

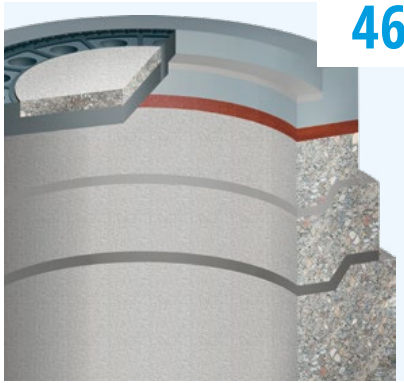

DENSOLASTIC®-EM

Two-component, durable and **permanently elastic** plastic mortar for dynamically-loaded joints.

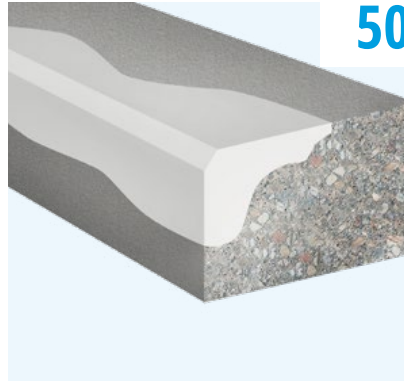

TOK®-Crete 45

High early strength repair mortar for the restoration of concrete surfaces.



TOK®-Dur

Two-component **coating compound** to level out unevenness in asphalt and concrete surfaces.



TOK®-Rep

Innovative, two-component cold-processed **repair compound**. Particularly suitable for the repair of surface damage. For example, scores after a punctured tyre in porous and conventional asphalt road surfaces.



TOK®-SK Rissband & TOK®-Band Spezial Rundstrang

System solutions to **treat cracks** in road construction.

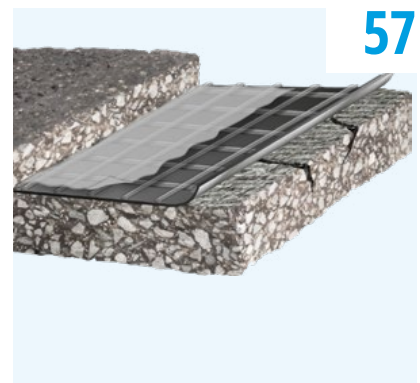

TOK®-Armabit SK

Asphalt reinforcement made from a polymer-coated, high-tensile fiber mesh with ultralight nonwoven fabric and a laminated bituminous sheeting, which delays joint reflection cracks.

DENSOLASTIC[®]-EM/-EM-G

Two-component durable and permanently elastic plastic mortar for dynamically-loaded joints.

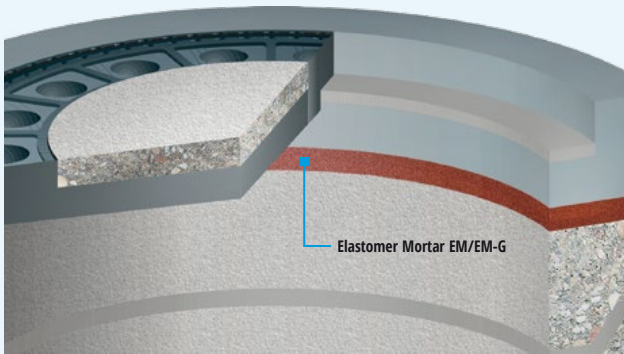

-  Permanently elastic.
-  Vibration damping.
-  For highest levels of static and dynamic loads.
-  High resistance against frost and de-icing salt.
-  Quick reopening to traffic possible.

DENSOLASTIC[®]-EM consists of a two-component polyurethane-based material with a filler content. The material can be delivered as a pourable version (EM-G) or as a spatula version (EM). The elastomer mortar is highly stable after it hardens and permanently elastic. Official testing by independent testing laboratories have proven the excellent

material properties of **DENSOLASTIC[®]-EM**. Dynamic fatigue loading was examined during the tests, among other things. **DENSOLASTIC[®]-EM** was, compared to mineral-based mortars, still in a perfect condition even after over 150,000 load cycles.

Usage

DENSOLASTIC[®]-EM is used for joints on components which are subject to high levels of dynamic and static loading. For example, it is used as a joint mortar in manhole

construction in heavily loaded roads, particularly with truck traffic. Due to its elasticity, **DENSOLASTIC[®]-EM** is noise and vibration dampening.

Application

Prepare the substrate

Coat the dry and clean substrate with **DENSOLASTIC[®]-E Primer E** and allow it to dry. The primer is required, for example, if a liquid-tight connection is required between the elastomer mortar and the contact surfaces. Before applying the support ring or similar aid, the spacer must be installed as the mortar cannot bear a load initially. The spacer must be as elastic as the mortar, otherwise it must be removed later. The cavities left in this case must also be closed with the elastomer mortar.

Processing the DENSOLASTIC[®]-EM

The outside temperature and the temperature of the components must be above +5°C (+41°F). Pour the complete contents of the component B into the component A container and mix the combined components together thoroughly with an electric stirrer with at least 500 rpm. The stirring time for the small containers is at least 3 minutes, and for the large containers, at least 4 minutes. Use a trowel, or similar, to work the elastomer mortar quickly, for the free-flowing material, pour it in place. Before casting, place a separating film made from PE or similar between the mortar and the form-work. The processing device should then either be immediately cleaned with acetone, or mechanically cleaned once the material has hardened.

At room temperature (approx. +23 °C/+73.4 °F) sufficient hardness will have been achieved after an hour so that the traffic can normally then be released. At lower temperatures, the material takes longer to harden.



Typical Product Properties (Excerpt*)

Technical data	Unit	Value
Pot life (temperature-dependent)	Minutes	15 (appr.)
Density	g/cm ³	1.10 (appr.)
Shore hardness A	-	60 – 80 (appr.)
Load capacity after installation*	hours	1 (appr.)
Volume change during freeze-thaw cycles	%	< 2

*Hardening to the point where it can be loaded is highly temperature-dependent and it can take longer at lower temperatures!

*** For more product information as well as details on ordering and packaging, please refer to the product data sheet at denso-group.com.**

DENSOLASTIC®-EM

Long term practical experience.



1999

Installation

Freimersdorfer Weg, Cologne
Previously, the manhole needed to be repaired twice a year as a conventional joint mortar was used.

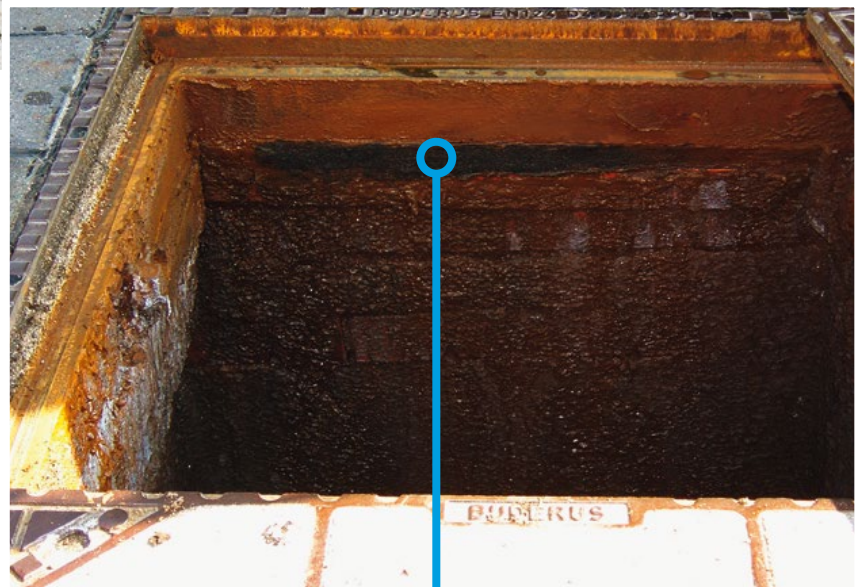

After 15 Years

Thanks to the use of DENSOLASTIC®-EM, the material hardness is still perfect even after being subjected to loads for many years. The product is the first elastic plastic mortar able to cope with extreme loads. It acts like a buffer between rigid elements, absorbing vibration without being damaged by it.

Thanks to DENSOLASTIC®-EM, an expensive annual program of roadworks has been replaced with long-term, year-round unhindered flowing traffic.



DENSOLASTIC®-EM – Advantages

Tested by the IKT
(Institute for Underground Infrastructure GmbH)

➤ Compression tests with restricted transverse strain

Here, the force-deformation behaviour of the material was tested at various temperatures and different loading rates.

Summary / practical applicability

The older the sample was, the smaller the deformation and therefore the higher the tension. The material behaved in the same way with increased material temperature and with higher loading rates.

As the loading rates on the road are normally very high and intensive, the deformation in this case is also small.

➤ Tests for shrinkage and swelling behaviour

After 24 hours, the maximum value for swelling was approximately 0.1%, and for shrinkage, it was approximately 0.07% after 28 days.

Summary / practical applicability

This means that the calculated value for shrinkage was significantly below the limit value for cement-bonded casting systems. For swelling, there is no limit value specified, however, the value of 0.1% is negligible.

This means that the elastomer mortar does not swell or shrink after installation and the joint height remains unchanged.

➤ Adhesion tests on coated bearing rings made of concrete

Adhesion tests were carried out with and without primer. The mean value without primer was 0.38 N/mm², with primer 0.64 N/mm².

Summary / practical applicability

Despite the relatively poor quality of the concrete, good adhesion to the substrate could be achieved. When Primer E was used, the adhesive bond strength could even be almost doubled.

Therefore, the shear forces can be absorbed as a joint is ensured between the plastic mortar and the contact surfaces.



Installation in areas that are subjected to high static and/or dynamic loads: Unlike conventional mortars for manhole joints, the elastic **DENSOLASTIC®-EM** prevents manhole covers from sagging.

➤ Testing the freeze/thaw resistance with the CDF test

The mean weathering after 28 days of freeze/thaw cycles was 334 g/m² and a 95% quartile of 419 g/m² – this is significantly below the permissible

limits of 1500 g/m² as the mean or 1800 g/m² for the 95% quartile.

Summary / practical applicability

Even harsh winters and enormous effects of road salt do not damage the material.

➤ Testing prisms under cyclical loading

To test what effect the load frequency has on the deformation behaviour of the material, the test samples were subjected to cyclical loads in a fatigue testing machine.

Summary / practical applicability

Independently of the load frequency (1, 3 and 5 Hz), no significant relationship could be determined between the load frequency and the deformation. An increase in the load frequency

caused no change to the deformation behaviour. The recovery of the test specimen was approximately 99% in all samples, i.e. with cyclical loading only negligible residual deformations remained.

➤ Creep tests on prisms over 72 hours (with and without freezing pre-treatment)

To test the creep behaviour of the material, the test prisms were loaded with constant tension over 72 hours.

Summary / practical applicability

This trial simulates the case that, for example, a HGV is parked for a long period of time on a manhole cover. The samples (with and without freezing pre-treatment) had an almost identical deformation behaviour after 72 hours. After initial

deformation occurred, there were only small deformations until the final deformation was reached. After the samples were removed, these recovered to approximately 99%, so that even after a creep load, only very small residual deformations remained.

When rigid mineral mortar cannot withstand dynamic traffic loads over the long-term, **DENSOLASTIC®-EM** provides long-lasting standards.



TOK®-Crete 45

High early strength repair compound for renovation of concrete surfaces or high-traffic industrial flooring.

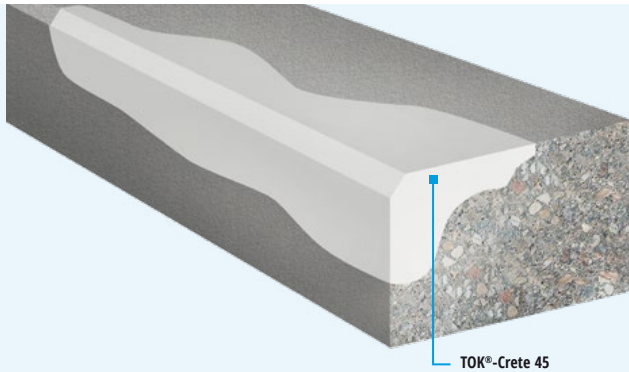

- ✓ Allwetteranwendung.
- ✓ Can be loaded after 45 minutes.
- ✓ Ideal für die Reparatur von Kantenschäden und Löchern.
- ✓ Sehr gute Haftung zum Untergrund.

TOK®-Crete 45 is a one-component, hydraulically setting mortar with selected aggregates. Along with its high early strength, **TOK®-Crete 45** has a very good level of resistance to freeze/thaw loading with and without de-icing agents. Depending on the kinds of loads

expected, roads can be opened again to traffic at +20 °C (+68 °F) after only 45 to 60 minutes.

Usage

The material was developed especially for the renovation of concrete road surfaces with edge damage and corner breakage, as well as for filling potholes and larger cracks. One further application is the renovation of slotted channels in road surfaces.

TOK®-Crete 45 can also be used to secure railing posts and can be deployed to secure runway and apron lighting in place at airports. Damage to high-traffic industrial flooring can be repaired without needing to be cordoned off for long periods of time.

Application

Ambient conditions

TOK®-Crete 45 can be worked at temperatures from -10 °C to +30 °C (+14 °F to +86 °F). The material temperature should be approximately room temperature (15–20 °C/59–68 °F) during working.

Subsurface preparation:

Sand, dust, oil, petrol and other loose particles must be removed from the surface. The normal application thickness is 10–60 mm; it can be up to 100 mm for individual cavities. The contact surface to the subsurface must be rough.

Installation:

Any exposed reinforcements must be pre-treated accordingly. Dampen the contact surface with water; standing water must be avoided, however. The mixing ratio of **TOK®-Crete 45** to water is 100: 6 (parts by weight), i.e. 20 kg of dry mortar is mixed with 1.2 l of water. We recommend preparing the required quantity of water in a separate bucket. After the dry material is added, it should be mixed for 2–3 minutes using a power mixer at medium speed until a uniform consistency is achieved. The material must be installed within approx. 10 minutes after mixing. Once installed, the material must be immediately smoothed or contoured.

Caution:

- Never mix up more material than can be worked with in 10 minutes.
- If the ambient temperature drops, mixing time may need to be increased.

Working temperature < +5 °C (+41 °F)

At lower temperatures, preheat the **TOK®-Crete 45**, water, mixer and accessories to room temperature (15–20 °C/59–68 °F). At temperatures below freezing – or if the subsurface is frozen – the contact surface should also be warmed using a heat gun or similar tool. After installation, the freshly-installed material should be protected with an insulating material for about 1 to 3 hours.

Working temperature > +25 °C (+77 °F)

Avoid direct exposure to sunlight. Keep the **TOK®-Crete 45**, water and equipment at room temperature (15–20 °C/59–68 °F). If necessary, use cold water.

Reworking

Special reworking materials are not necessary. If **TOK®-Crete 45** needs to be given a coating, the mortar must be dried out sufficiently. The compatibility of the coating and **TOK®-Crete 45** should be tested in advance.

Recommendations for processing, boundary conditions and reworking must be observed in accordance with DAfStb RiLi-SIB and ZTV-ING.

Health and safety at work

For information on this topic, please consult the safety data sheet.

TOK®-Crete 45 is not a hazardous substance as defined by the German Hazardous Substances Regulation.

Typical Product Properties (Excerpt*)

	Unit	Result	Remarks
Mixing ratio	-	100 : 6	20 kg dry mortar with 1.2 l of water
Working time	Minutes	10–15 (approx.)	At +23 °C/+73.4 °F
Bulk density	kg/dm ³	2.20 (approx.)	At +23 °C/+73.4 °F
Compressive strength after 2 hours	N/mm ²	16 (approx.)	At +23 °C/+73.4 °F
Compressive strength after 8 hours	N/mm ²	45 (approx.)	At -5 °C* (+23 °F)
Compressive strength after 28 days	N/mm ²	> 45	At +23 °C/+73.4 °F
Young's modulus after 28 days	N/mm ²	30,000 (approx.)	At +23 °C/+73.4 °F
Weathering quantity in freeze/thaw cycles	kg/m ²	< 0.1	Average value

* For more product information as well as details on ordering and packaging, please refer to the product data sheet at denso-group.com.

TOK®-Crete 45 – Application

Repairing concrete damage on an airport surface



Airfield concrete surface

Take-off and landing runway at Leipzig Airport



Preparation

The prepared surfaces should be moistened. Priming is not required.



Mixing

TOK®-Crete 45 is mixed with water (20 kg = 1.2 litres of water).



Installation

Then install quickly as the pot life is 10 minutes.



Installation

It is recommended that 2 people work on larger projects so that 'fresh on fresh' can always be installed.



Smoothing

The smoothing or removal of any excess material must be done immediately. After 8 hours a compressive strength of approximately 30 N/mm² is reached.

Repairing a slotted channel on a national highway



Damage to the slotted channel

Concrete chipping in a slotted channel.



Shuttering and installation

Shuttering, mix up the material, install. Wait a short period of time. Remove the shuttering.



Repair is ready

Pack up. Finished.

TOK®-Dur

TOK®-Dur is a two-component material based on acrylic resins.

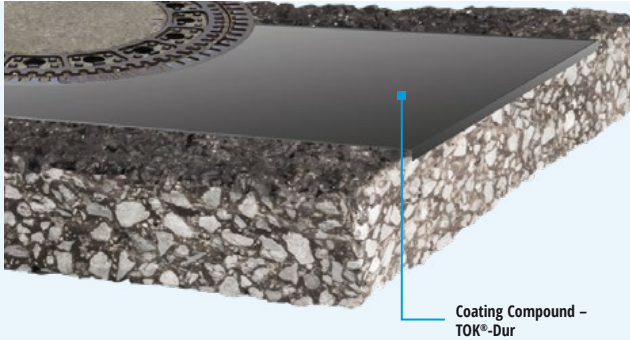

-  Very simple and easy workability.
-  Permanent and abrasion-resistant.
-  Traffic flow restored quickly.
-  Good surface grip if sprinkled with grit.

TOK®-Dur is used to create durable, abrasion-resistant and weather-resistant coatings for covering over fine cracks or to compensate for minor unevenness, primarily on asphalt surfaces.

The powder hardener TOK®-Dur (B components) is subject to the Chemicals Prohibition Ordinance (Chemikalienverbotsverordnung)

Usage

TOK®-Dur is used to make joints in porous asphalt road surfaces. Due to its excellent material properties and the special cross-section which is water-permeable in the lower

area, a permanent and sealed connection is guaranteed. In addition, the mesh tape ensures that water drains away easily below the road surface.

Application

Subsurface preparation

The subsurface must be clean, dry and free of detritus. Any oil film or other adhesion-reducing substances must be removed. Asphalt surfaces with sealants are not suitable for coating with TOK®-Dur.

With concrete substrates, the two-component active primer must be applied first (mixing ratio 100:3). Active primer usage approx. 150 g/m².

The air temperature must be at least +5 °C (+41 °F) and the relative humidity must not be higher than 75%.

The subsurface temperature must be at least +3 °C (+37.4 °F) above the dew point and must not exceed +45 °C (+113 °F). Before application, we recommend briefly stirring or shaking the primer. The concrete subsurface must be in place for at least 4 weeks. The surface sinter course must be mechanically removed or stripped using a high-pressure water jet. The subsurface must be clean (free of dirt and soot).

Application of adhesive primer (for concrete subsurface only):

Spray application or using roller or brush. The primer must be applied uniformly in a thin coat. Avoid pooling. After waiting for the surface of the adhesive primer to dry, TOK®-Dur can be applied directly.

**Do not mix the active primer with solvent-based thinners!
Ensure that the product is applied in a thin coat!**

Application of the coating compound

The material must be stirred well before use, the powder-based curing agent must be homogeneously mixed in at a mixing ratio of 1:100. The material is ready for use and must not be diluted. Application is carried out using an adhesive/notched trowel. When applied in layers thicker than 5 mm, TOK®-Dur can be filled with (dry!) quartz sand of a grain size 0.3–1.5 mm, up to a maximum proportion of 50%. Application thickness should not exceed 20 mm wherever possible. With thicknesses of over 5 mm, the mixture should be applied in two separate steps.

To achieve a good surface grip, dress the surface immediately after material application with an excess amount of coloured quartz sand, blast furnace slag, or similar material, with a grain size of 0.3 to 1.5 mm. The excess dressing material can be reused. The ambient temperature must be at least +5 °C (+41 °F). The curing time is temperature-dependent and is approximately 1 hour. Application equipment should be cleaned immediately after work using ethyl acetate or a similar cleaner.

Typical usage of TOK®-Dur – with added quartz sand – is approx. 1.5–2.0 kg per m², depending on the nature of the subsurface.

In its pure form (without quartz sand), usage is approx. 1.6 kg/m² per mm of coat thickness.

Typical Product Properties (Excerpt*)

TOK®-Dur is a two-component, specialized product with a reactive acrylic resin as a binder. The material is characterized by the following properties:

- Good elasticity
- Low shrinkage stress
- Rapid drying and good adhesive strength
- Good weather resistance and durability
- Good water and road salt resistance

Product Properties	Unit
Density	1.60 g/ml (approx.)
Flash point	+10 °C (+50 °F) (approx.)
Pot life at 23 °C	10 minutes (approx.)

*** For more product information as well as details on ordering and packaging, please refer to the product data sheet at denso-group.com.**

TOK®-Dur – Application

Levelling off unevenness around a manhole



Shaft damage

After restoring the destroyed mortar joint with an elastomer mortar, the road surface is normally under the height level of the manhole ring.



Masking surfaces

Mask the surfaces to obtain a clean overall appearance.



Mask the manhole ring

The manhole frame should also be masked off.



Coating compound

Coating compound and hardener component.



Mixing

Stir up the coating compound. Then add the hardener and mix well. If required, fill with quartz sand somewhat to pre-fill large uneven surfaces.



Apply

Finally, apply the compound. It is possible to repeat the application.



Sprinkling

Then sprinkle the surface (e.g. blast furnace slag or coloured quartz sand) to ensure good surface grip. The colour of the sprinkling material determines the colour of the finished coating.



Removing the masking tape

After an approx. 1 hour wait, the masking tape can be removed.







Finished levelling layer

Finally the excess material used for sprinkling is swept off. Traffic can then be released.

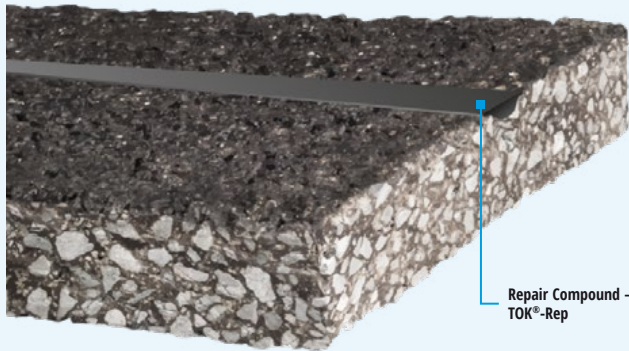
TOK®-Rep

Innovative, two-component, cold-worked repair compound. Especially suitable for repairing surface damage – such as scoring after tyre blowouts, for example – in porous and conventional asphalt wearing courses.



-  Rapid working and material hardening – roads can be re-opened to traffic quickly.
-  Good mechanical abrasion resistance.
-  Very good compound adhesion to asphalt.
-  Due to the material consistency, cavities in porous asphalt remain open.

Incidents of mechanical damage occur over and over again, particularly in porous asphalt wearing courses. Grooving frequently occurs when tyres are damaged on HGVs and the rims are dragged over the asphalt from full speed to a complete stop. These types of grooves can be up to 3 cm wide and approx. 1-3 cm deep. The damage to the surface can have an adverse effect on traffic safety, while also acting as a starting point for further, more serious damage to the wearing course. **TOK®-Rep** now gives you the option of quickly and safely remedying such damage in order to avoid any further deterioration in surface quality.

With porous asphalt wearing courses, care must be taken to leave a sufficiently porous area of the wearing course under the scoring to allow water to drain off. If the surface damage is serious enough to prevent repairs being carried out using this compound, we recommend milling off the damaged area and installing a new surface. The proper joint connections can then be created using our special joint tape, **TOK®-Band SK Drain**.

Application

Preparation of the damaged areas

The contact surfaces must be clean and dry. Loose aggregate components must be removed. The damaged areas (for purely aesthetic reasons) can be masked at the sides with masking tape.

Working the compound

Components A and B are mixed together with a mixer (e.g. drill with mixing blade Collomix WK 70) for 1–2 minutes at a rotation speed of max. 500 rpm (ensure that as little air as possible is introduced into the mixture). The A component should be first stirred separately. The container pairs (A+B) must be added together as they were assembled and delivered in the box, so that the required mixing ratio is observed. The mixed material is cast immediately afterwards. The surface temperature of the asphalt must be at least +5 °C and at most max. +40 °C (+41 °F to +104 °F). The dew point must be observed. Any rising air bubbles must be removed (e.g. by painting over with a brush, or by briefly scorching with a gas burner) before the compound solidifies. The installed compound can then be smoothed off and levelled with a trowel. To achieve sufficient surface grip, it is necessary to sprinkle the compound with an excess of grit after it has been poured. For this, we recommend a grit with a PSV value (Polished Stone Value) of 40 to 60, grain size approx. 0/5. It is vital to ensure that the grit is dry when applied. If the grit is damp, the fresh **TOK®-Rep** can foam up under certain circumstances.

Depending on the weather, the material must be kept dry for 10 to 20 minutes after it has been installed (at +23 °C/+73.4 °F). The material should then be protected as far as possible from moisture until it hardens. The masking tape applied to the sides of the repair area should be removed immediately after pouring and gritting. Approx. 60 minutes after application (at +23 °C/+73.4 °F), the compound is usually hardened to an extent where the road can be reopened to traffic. After approx. 24 hours (at approx. +23 °C/+73.4 °F), the compound is tack-free and completely hardened. The pot life and hardening time are temperature dependent. They shorten at higher temperatures and lengthen at lower temperatures.

Cleaning tools

Tools and working equipment can be cleaned using acetone. Already-hardened material can be removed mechanically.

Typical Product Properties (Excerpt*)

Technical data	Unit	Value
Density (A+B, hardened)	kg/l	1.45 (approx.)
Colour	-	Black
Mixing ratio (A:B, parts by weight)	-	4:1
Pot life	Minutes	4–6 minutes (approx.)

* For more product information as well as details on ordering and packaging, please refer to the product data sheet at denso-group.com.

TOK®-SK Rissband

Self-adhesive bituminous profile strip used to repair cracks in road construction.

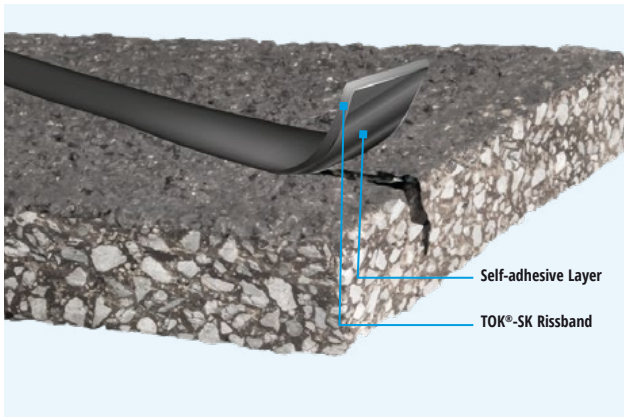

Cold processed – no burner required.



Fulfils all requirements of ZTV Fug-StB 15.



Processing temperature from +5°C to +50°C (from +41°F to +122°F).

TOK®-SK Rissband is a high-quality bituminous profile strip made from polymer-improved road bitumen for the fast and cost-effective repair of damage on asphalt roads.

TOK®-SK Rissband has a homogeneous full-surface adhesive coating on one side, allowing it to be applied to cold asphalt quickly and safely – without the use of a gas burner.

Usage

TOK®-SK Rissband is ideal for covering cracks and open joints or seams in asphalt road surfaces. The maximum width of the crack opening should not exceed 5 mm. The profile strip can be applied quickly and safely without the use of a gas burner.

Damaged areas can be permanently sealed, as **TOK®-SK Rissband** is highly plastic and can be pressed into position using a roller.

Application

Weather conditions:

The weather conditions should match those specified in ZTV Fug-StB (bitumen joint tapes). **TOK®-SK Rissband** should therefore only be applied in dry weather and when the surface temperature of the asphalt is at least +5°C (+41°F).

At temperatures between 0°C and +5°C (+30°F and +41°F), the product may only be applied if additional measures are taken (e.g. preheating of base surface).

Requirements and usage of TOK®-SK Rissband:

The asphalt surface must be clean and dry. **TOK®-SK Primer** must be applied in advance; this product improves adhesion to the base surface. In summer, the drying time of the primer is just 3 to 5 minutes, depending on weather conditions, allowing further work to start quickly.

Application:

Once the **TOK®-SK Primer** is dry, **TOK®-SK Rissband** is applied to the crack with the adhesive layer facing down and pressed into place using a roller or the Rissband SK Roller (size 40x4 mm only).



The traffic using the road rolls the compound further into the crack. Under certain circumstances, it may be advantageous to grit **TOK®-SK Rissband** after it has been laid – for example, when laying at very high temperatures. The ambient and component temperature should be above +10°C (50°F) to guarantee good and permanent adhesion to the substrate. At lower temperatures, if necessary, it may help to carefully warm the substrate slightly. **TOK®-SK Rissband** is **not** suitable for the vertical formation of seams and connections; in such cases, the minimum profile thickness as specified in ZTV Fug-StB is 10 mm.

* For more product information as well as details on ordering and packaging, please refer to the product data sheet at denso-group.com.

TOK®-Band Spezial Rundstrang

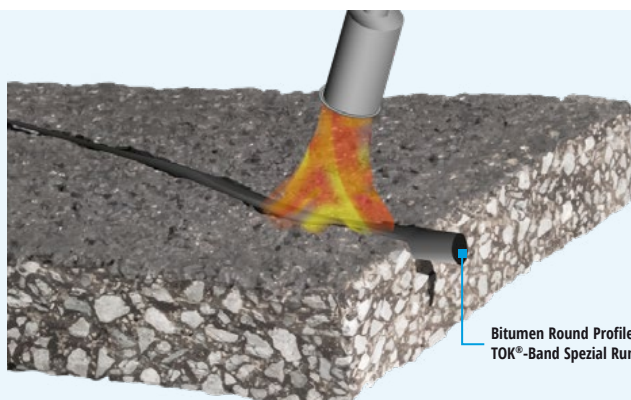
TOK®-Band Spezial Rundstrang is a bitumen round profile for a wide range of applications.



-  Simple to work with.
-  Suitable for use in sealing faulty cuts.
-  For cracks in asphalt wearing courses, also for crack widths >5 mm.

TOK®-Band Spezial Rundstrang is made from the same material as the tried and tested bitumen joint tape, TOK®-Band Spezial. Its rounded profile is used for sealing cracks, for example. Such cracks can even be greater than 5 mm wide. The round profile is worked into the crack as a filling. Other possible uses include the sealing of incorrect cuts in asphalt surfaces. Also sealable using the round profile are 'cross cuts', which are generated at corner points when cutting out rectangular sections.

Attention should be paid in the following: **TOK®-Band Spezial Rundstrang:**

- It should always be used with a primer (**TOK®-SK Primer**).
- At lower temperatures, the material should be pre-warmed using a burner, as it is easier to work with when heated.
- The material must be worked into the crack: merely 'laying' the round profile on the crack is not sufficient.
- Ideally, the installed round profile is then also covered with **TOK®-SK Rissband**.

Typical Product Properties (Excerpt*)

Test	Unit	Typical results range	Requirement
Softening point (Ring&Ball method)	°C / °F	> +100 (+212)	> +90 (+194)
Cone penetration	0.1 mm	20 - 50	20 - 50
Recovery	%	10 - 30	10 - 30
Cold bending behaviour	°C / °F	≤ ±0 (+32)	≤ ±0 (+32)
Stretch and adhesive strength	% / N/mm ²	≥ 10 / ≤ 1,0	≥ 10 / ≤ 1.0

* For more product information as well as details on ordering and packaging, please refer to the product data sheet at denso-group.com.

TOK®-Armabit SK

Fibreglass mesh asphalt reinforcement with ultra-light non-woven material and laminated bitumen layer – for less cracking

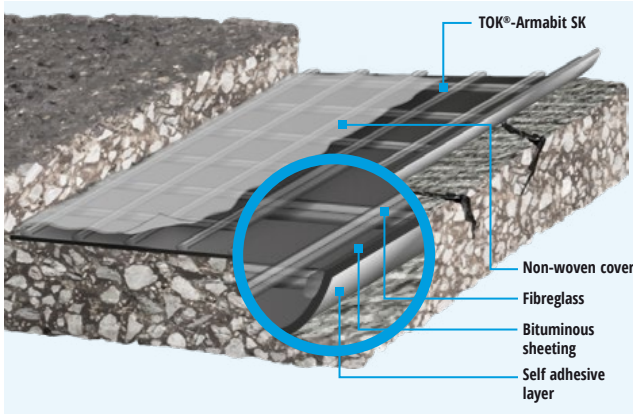

High tensile strength ≥ 100 kN/m in longitudinal and transverse directions



Self-adhesive on one side – easy & fast application



Shelf-stable and resistant to installation damage

TOK®-Armabit SK is an asphalt reinforcement comprised of a strong polymer-coated fibreglass mesh combined with an ultra-light non-woven material and a laminated film-protected bitumen layer. The reinforcement prevents cracks from forming and extends the service life of the road.

TOK®-Armabit SK is self-adhesive on the application side, making it easy and fast to apply the reinforcement. **TOK®-Armabit SK** is tested and approved to EN 15381 standards. The product complies with FGSV paper no. 770 "Working paper on the use of non-woven materials, mesh and composites in asphalt road construction".

Usage

TOK®-Armabit SK is used in the repair and renovation of asphalt surfaces and is designed to increase the service life of the road, and particularly of the wear layer (cover layer). **TOK®-Armabit SK** is ideal for use as an asphalt layer in concrete surfaces that will be

covered with asphalt. The product slows down the rate at which cracks in the concrete joints transfer through to the asphalt. It also significantly lengthens maintenance intervals.

Application

In general, the installation and application instructions (chapter 11 of the FGSV "Working paper on the use of non-woven materials, mesh and composites in asphalt road construction") apply.

Environmental conditions:

TOK®-Armabit SK can be used at temperatures between 5°C and +30°C (+41°F to +86°F).

Surface preparation

Sand, dust, oil, petrol and other loose particles must be removed from the surface. To ensure that **TOK®-Armabit SK** establishes full contact with the surface, the surface must be profiled before application if it is very uneven or has potholes or steep transitions. Expansion joints or large cracks must be sealed before application using a hot-processed bitumen joint compound in compliance with ZTV Fug-StB. On milled surfaces, the milling depth must not exceed 10 mm.

When using **TOK®-Armabit SK**, a binding agent must be applied in compliance with TL BE-StB; this is particularly important on concrete surfaces. The bitumen emulsion must be fully broken before the asphalt reinforcement is applied to ensure that no moisture is sealed into the layer.

Installation of the asphalt reinforcement

TOK®-Armabit SK may only be installed in dry weather and on dry surfaces. Lay the strips side by side without any overlap, with the adhesive side facing down.

After rolling out, the asphalt layer must be pressed down onto the surface to ensure good adhesion. This can be achieved using a brush or a small roller. The asphalt layer must be applied in areas of tensile stress. Around joints and cracks, ensure an installation width of 50 cm on other side of the joint or crack. In exceptional circumstances and in consultation with the client, an installation width of 25 cm on either side of the joint or crack may be sufficient.

TOK®-Armabit SK must not be driven over before the mix has been added! The asphalt mix should be added no later than one day after the installation of the asphalt layer. If the truck delivering the mix must drive over the asphalt reinforcement, it may be necessary to chip off a grain size of 2/5 mm at a rate of 1.0 kg/m² from the material, particularly if the weather is hot. This will prevent the material from sticking to the tyres. The truck delivering the mix must drive over the surface as carefully as possible. Avoid sudden steering movements or harsh acceleration or braking. The generally recognised rules and standards for asphalt road construction apply to the installation and compression of the mixed material.

TOK®-Armabit SK must be covered with an asphalt layer that is at least 4 cm thick (when compressed). This is the only way to ensure that the combined asphalt and asphalt reinforcement layer will be effective.

Further information can be found in the application instructions for **TOK®-Armabit SK**.

Typical Product Properties (Excerpt*)

Property	Typical value	Applicable standard
Colour	Black	
Fibre type	100% fibreglass, multi-filament	
Coating	Temperature-resistant modified polymer coating	
Bitumen layer	Elastomer bitumen, approx. 2 kg m ²	
Mesh width	≈ 12,5 x 12,5 mm	
Weight/surface content	≈ 2500 g/m ²	DIN EN ISO 9864
Tensile strength	Longitudinal / transverse ≥ 100 kN/m	DIN EN ISO 10319
Elongation at rated force	Longitudinal / transverse $\leq 3\%$	DIN EN ISO 10319

* For more product information as well as details on ordering and packaging, please refer to the product data sheet at denso-group.com.



REPAIR ASPHALT

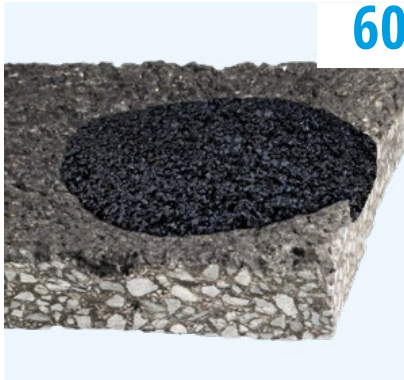

TOK®-Fill 2/5
Cold-worked repair asphalt
for roads and traffic areas.

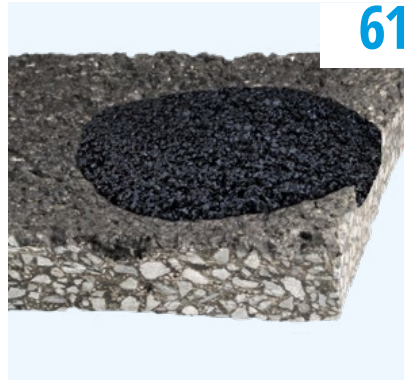

TOK®-Fill Aqua 0/5
Reactive cold-worked repair asphalt
for roads and traffic areas.

TOK®-Fill 2/5

TOK®-Fill is a repair asphalt for filling potholes and similar imperfections in roads and other traffic areas.



All-weather usage at temperatures from -10 °C to +25 °C (+14 °F to +77 °F), even on damp surfaces.



Ideal for repairing potholes.



Can take traffic loads immediately.



Solvent- and tar-free.

TOK®-Fill is manufactured from gravel, bitumen and special additives. This composition guarantees simple product application and long-lasting durability.

Official testing has shown that the stability is comparable with hot-worked asphalt even when measured long after installation.

Usage

TOK®-Fill meets the highest load demands and can be used universally: e.g. on roads with the highest traffic loads, side streets and industrial traffic areas. In addition, TOK®-Fill is suitable for sealing the road surface after civil engineering work,

as well as for road connections at level crossings (tramlines, railway crossings etc.). The product can be installed even if the subsurface is damp.

Application

TOK®-Fill can be applied mechanically onto a load-bearing subsurface; on smaller areas, a shovel can also be used. Remove loose parts before installation. If the installation thickness exceeds 4 cm, TOK®-Fill must be installed in layers. The maximum total installation thickness is 18 cm.

TOK®-Fill must be installed with a slight excess, so that subsequent compaction results from the movement of traffic. Mechanical compacting is advantageous but not absolutely necessary. The product can be installed even in wet weather (damp conditions or even rain) at temperatures from -10 °C to +25 °C (+14 °F to 77 °F). No standing water should be present in the installation site itself.

As temperatures fall (under +5 °C/+41 °F), the material becomes a little more solid and should in this case be warmed up (in a heated storage room for example) so it can be worked more easily.

The area where TOK®-Fill has been installed does not need to be sanded and can take vehicle traffic immediately without additional work.

It should be noted that the material is not fully hardened immediately after installation.

The hardening time is also temperature-dependent and can take longer at higher temperatures. When used in radial areas or where pivotal point loads may occur (such as car parks), the installed material should only be subjected to loads once sufficient stability has been achieved. In such cases, we recommend using of our reactive, quick-hardening product, TOK®-Fill Aqua.

Typical Product Properties (Excerpt*)

Grain size in mm	2/5, installation thickness from 2 to 5 cm per layer
Application temperature (ambient)	-10 °C to +25 °C (+14 °F to +77 °F), incl. on damp subsurface
Density	2.0 g/cm ³ (approx.) (compacted)
Usage	Approx. 80 kg/m ² (compacted, 4 cm installation thickness)
Colour	Black

* For more product information as well as details on ordering and packaging, please refer to the product data sheet at denso-group.com.

TOK®-Fill Aqua 0/5

TOK®-Fill Aqua is a repair asphalt for filling potholes and similar imperfections in roads and other surfaces used by traffic.



All-weather usage at temperatures from -10 °C to +45 °C (+14 °F to +113 °F), even on damp surfaces.



Ideal for repairing potholes.



Hardens rapidly after about 1 h – **reactive** system.



Solvent- and tar-free.

TOK®-Fill Aqua is a high-performance mixture for minor repairs to all types of road surface. It consists of a mixture of high-grade chippings and sand, plus a polymer-modified

bituminous binder containing specialized additives. After application, the material hardens very rapidly.

Usage

TOK®-Fill Aqua is used to for minor repairs, road crossings, damaged footpaths, roadway footbridges, pipe trench damage, for the filling-in of boreholes after sampling, filling-in

of potholes and frost damage, ramp structures on slip roads, for levelling work, and for making modifications to roadway installations.

Application

Subsurface

TOK®-Fill Aqua can be installed at any time. The areas to treat must be cleared of loose detritus and dirt. The subsurface can be slightly damp. For a better adhesion, the contact surfaces can be pretreated with an adhesive.

Application conditions

Application is weather-independent and can take place at any time that outdoor temperatures are between -10 °C and +45 °C (+14 °F to +113 °F).

Application tip

The bulk material can be very easily poured into the damaged area. To ensure optimum workability at low temperatures, the material should have been stored before using at room temperature (approx. 15–20 °C/59–68 °F). Additional heating with a naked flame should be avoided and is not advisable, since this may cause damage to the binder. The material is installed with a slight excess and spread, at first without compaction. As a final step, the installed material is then compacted using a tamper, a lightweight roller or a vibrating plate.

The hardening process can be accelerated by moistening and mixing the bulk mixture well before compacting.

The surface can be opened to road traffic immediately after installation. If road use is very heavy, the surface should not be opened to traffic for about an hour. Longer hardening times can be expected at temperatures near the freezing point.

Typically, the bulk mixture can be installed in a single layer of up to 4 cm. To ensure better compaction and the greater level of stability that this achieves, at least two layers should be used if a higher installation thickness is required.

Typical Product Properties (Excerpt*)

Grain size in mm	0/5
Application temperature (ambient)	-10 °C to +45 °C (+14 °F to +113 °F), incl. on damp subsurface
Density	2.0 g/cm ³ (approx.) (compacted)
Usage	Approx. 80 kg/m ² (compacted, 4 cm installation thickness)
Colour	Black

* For more product information as well as details on ordering and packaging, please refer to the product data sheet at denso-group.com.



TRACK CONSTRUCTION PRODUCTS

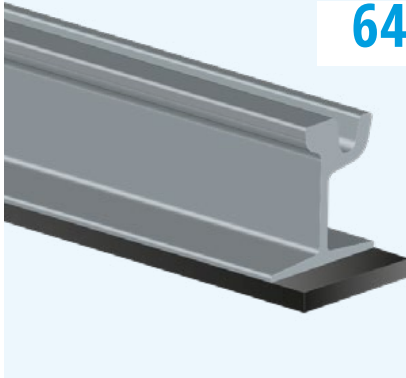

DENSOLASTIC®-SU

Elastic after hardening, two-component pouring compound based on PU. Vibration damping and noise reducing.



TOK®-Riegel (TOKOMAT®)

Bitumen joint tape extrusion, approved according to ZTV Fug-StB.

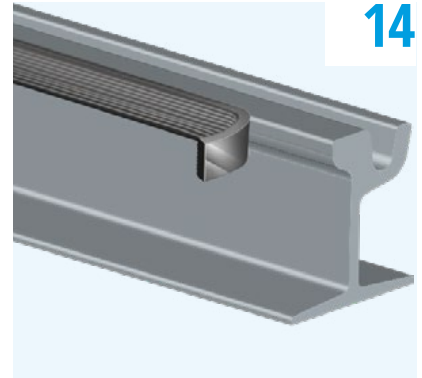

TOK®-Band SK N2

Highly flexible self-adhesive, bitumen joint tape.

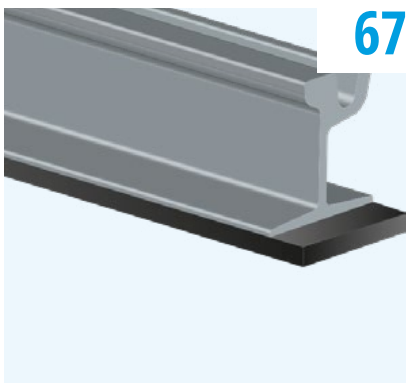

TOK®-Melt SU

Plasto-elastic hot pouring compound based on polymer-modified bitumen, hot processable, stable and resistant to surface pressure.

DENSOLASTIC®-SU 45

Elastic hardening, vibration damping pouring compound with low shore hardness for rails, bollards and gate valves.

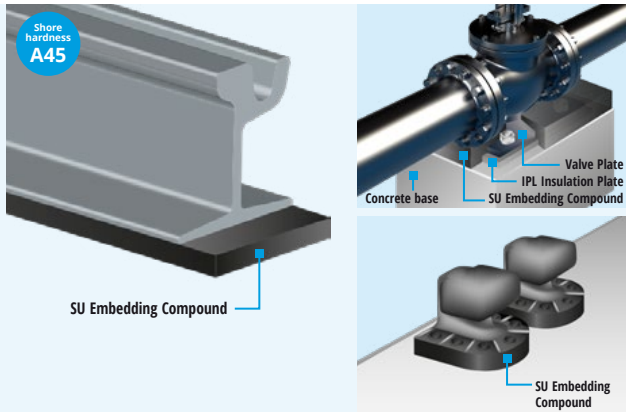

Permanently elastic and vibration damping.



Easy to apply.



Tested according to VDV Notice 6201.



Chemically and mechanically resistant.



For numerous fields of application e.g. rails, mooring bollards and fitting foundations (sliding feet).

DENSOLASTIC®-SU 45 consists of a pourable, two-component polyurethane-based system that cures into an elastic material.

DENSOLASTIC®-SU 45 is frost- and road salt-resistant. Approximate average use: 10 kg/m² per cm material thickness.

Usage

DENSOLASTIC®-SU 45 is ideal for use as an elastic and vibration-damping pouring compound for grooved rails and filled section rails as well as for mooring bollards and fitting foundations (sliding feet). The material is suitable for light railway transportation or when greater deflection is required in the system (e.g. as a pouring compound for machine

components).

DENSOLASTIC®-SU 45 is used in pipeline construction as an isolation layer in valve foundations and in port construction as a protective mass for bollards.

Application

Subsurface preparation

The subsurface may be slightly damp. Any oil or grease film present must be removed if permanent joining of the material to the contact area is desired. Dust and other soiling must be removed, as must water, ice or snow. An application of **DENSOLASTIC®-E Primer** can be used to improve the bond strength across a range of subsurfaces (e.g. steel and concrete).

The components must be carefully mixed using a slowly rotating mixer (max. 500 rpm) for about 60–70 seconds. Any material adhering to the sides must be cleaned off and mixed with the rest.

To ensure preparation is rapid and of a high quality, always use a 2-component dosing machine. The air and subsurface temperature should be between +5 °C (+32 °F) and +35 °C (+95 °F). The material's pot life also depends on the ambient temperature. At room temperature, a pot life of 4–6 minutes can be assumed (incl. time for premixing). The pot life decreases for higher temperatures. The material is tack-free after 2 hours and fully load-bearing after approx. 24 hours.

Preparing the material

Mixing ratio A : B = 100 : 16 (weight), A : B = 100 : 8.8 (volume).

Always ensure that component A has been stirred thoroughly through before working. Following this step, the entire contents of component B are added.

Typical Product Properties (Excerpt*)

DENSOLASTIC®-SU 45 is characterized by the following properties:

- Vibration-reducing
- Chemically and mechanically resistant
- Permanently elastic: in vibration testing, no effects were observed after 3 million load cycles
- Long-term resistance to temperatures from -20 °C to +70 °C (-4 °F to +158 °F)
- Resistant to water, saline solution (10%), sodium hydroxide solution (5%) and engine oil (SAE 10 W 40)
- Short-term resistance to diesel fuel
- Electrically insulating
- Medium hardness, in accordance with VDV Notice 6201

Determination of the secant modulus between 0 and 50 kN using the load-deflection curve. Test specimen dimensions (1000 x 188 x 25) mm and emplaced Ri 60 grooved rail with a length of 1000 mm. Load rate 6 kN/min. with centred point of loading.

Deformation under load – DENSOLASTIC®-SU 45

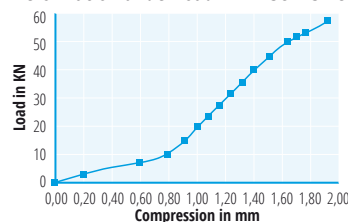

Curing process at +23 °C (+73.4 °F)

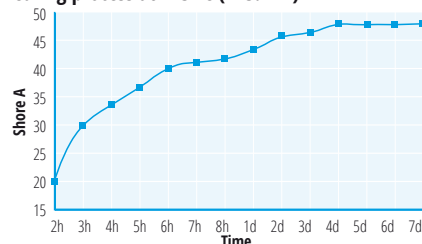

Pot life	4-6 min. (approx.)
Density (cured)	0.72 kg/l (A+B component)
Shore hardness A	45 ± 5
Tear strength	1.6 N/mm ² (approx.)
Elongation after fracture	170% (approx.)
Rebound elasticity	40% (approx.)
Tear resistance	6.5 N/mm (approx.)
Bond strength	1.4 N/mm ² (approx.)

* For more product information as well as details on ordering and packaging, please refer to the product data sheet at denso-group.com.

DENSOLASTIC®-SU 65

Elastic hardening, vibration damping pouring compound with medium shore hardness for rails and bollards.

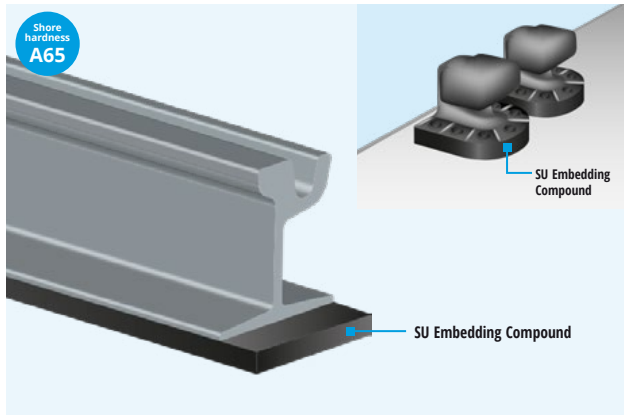

- Permanently elastic and vibration damping.
- Easy to apply.
- Tested according to VDV Notice 6201.
- Chemically and mechanically resistant.
- For numerous fields of application e.g. rails and mooring bollards.

DENSOLASTIC®-SU 65 consists of a pourable, two-component polyurethane-based system that cures into an elastic material. DENSOLASTIC®-SU 65 has short-term resistance to diesel fuel, and is also frost- and road salt-resistant.

Usage

DENSOLASTIC®-SU 65 is used as an elastic and vibration-dampening embedding compound for grooved rails and full web rails and bollards.

Application

Subsurface preparation

The subsurface may be slightly damp. Any oil or grease film present must be removed if permanent joining of the material to the contact area is desired. Dust and other soiling must be removed, as must water, ice or snow. An application of DENSOLASTIC®-E Primer can be used to improve the bond strength across a range of subsurfaces (e.g. steel and concrete).

Preparing the material

Mixing ratio A : B = 100 : 16 (weight), A : B = 100 : 8.8 (volume).

Always ensure that component A has been stirred thoroughly through before working. Following this step, the entire contents of component B are added.

The components must be carefully mixed using a slowly rotating mixer (max. 500 rpm) for about 60–70 seconds. Any material adhering to the sides must be cleaned off and mixed with the rest. To ensure preparation is rapid and of a high quality, always use a 2-component dosing machine. The air and subsurface temperature should be between +5 °C (+32 °F) and +35 °C (+95 °F). The material's pot life also depends on the ambient temperature. At room temperature, a pot life of 4–6 minutes can be assumed (incl. time for premixing). The pot life decreases for higher temperatures. The material is tack-free after 2 hours and fully load-bearing after approx. 24 hours.

Typical Product Properties (Excerpt*)

DENSOLASTIC®-SU 65 is characterized by the following properties:

- Vibration-reducing
- Chemically and mechanically resistant
- Permanently elastic: in vibration testing, no effects were observed after 3 million load cycles
- Long-term resistance to temperatures from -20 °C to +70 °C (-4 °F to +158 °F)
- Resistant to water, saline solution (10%), sodium hydroxide solution (5%) and engine oil (SAE 10 W 40)
- Short-term resistance to diesel fuel
- Electrically insulating
- Medium hardness, in accordance with VDV Notice 6201

Determination of the secant modulus between 0 and 50 kN using the load-deflection curve. Test specimen dimensions (1000 x 188 x 25) mm and emplaced R1 60 grooved rail with a length of 1000 mm. Load rate 6 kN/min. with centred point of loading.

Deformation under load – DENSOLASTIC® SU 65

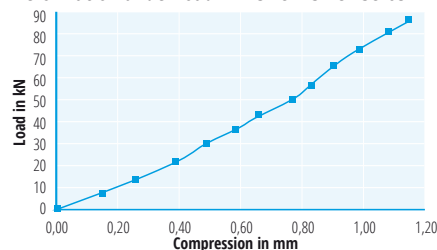

Curing process at +23 °C (+73.4 °F)

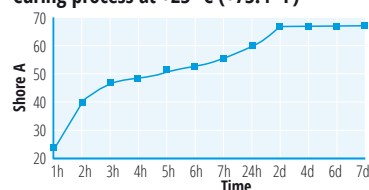

Topfzeit	ca. 4 Min.	
Dichte (ausgehärtet)	ca. 0,78 kg/l (A+B Komponente)	
Shore Härte A	65 ± 5	DIN 53 505
Zugfestigkeit	ca. 3,5 N/mm ²	DIN 53 455
Bruchdehnung	ca. 200 %	DIN 53 544
Rückprallelastizität	ca. 40 %	DIN 53 512

* For more product information as well as details on ordering and packaging, please refer to the product data sheet at denso-group.com.

DENSOLASTIC®-SU 85

Elastic hardening, vibration damping pouring compound with high shore hardness for rails and bollards.

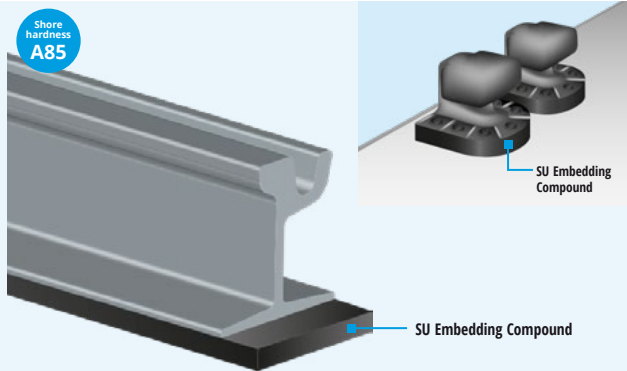

- Permanently hard-elastic.
- Easy to apply.
- Tested according to VDV Notice 6201.
- Chemically and mechanically resistant.
- For numerous fields of application e.g. rails and mooring bollards.

DENSOLASTIC®-SU 85 consists of a pourable, two-component polyurethane-based system that cures into an elastic material. **DENSOLASTIC®-SU 85** has short-term resistance to diesel fuel, and is also frost- and road salt-resistant.

Usage

DENSOLASTIC®-SU 85 is used as an elastic and vibration-dampening embedding compound for grooved rails and full web rails and bollards.

Application

Subsurface preparation

The subsurface should be dry. Any oil or grease film present must be removed if permanent joining of the material to the contact area is desired. If the subsurface is damp, this could lead to foaming effects affecting the fresh compound. The embedding compound must not be poured under standing water. Dust and other soiling must be removed, as must water, ice or snow. An application of **DENSOLASTIC®-E Primer** can be used to improve bond strength on concrete and steel.

Preparing the material

Mixing ratio A : B = 100 : 40 (weight), A : B = 100 : 25 (volume).

Ensure that component A has been stirred thoroughly through before working.

Following this step, the entire contents of component B are added. The components must be carefully mixed using a slowly rotating mixer (max. 500 rpm) for about 60–70 seconds.

Any material adhering to the sides must be cleaned off and mixed with the rest.

For rapid, high-quality preparation, a mechanical method is best, using a 2-component dosing machine.

The air and subsurface temperature should be between +5 °C (+32 °F) and +35 °C (+95 °F). The material's pot life also depends on the ambient temperature. At room temperature, a pot life of 4 minutes can be assumed (incl. time for premixing). The pot life decreases for higher temperatures. The material is tack-free after 2 hours and fully load-bearing after 24 hours.

If it becomes necessary to scuff off the projecting edge of the embedding material to be flush with the rail footing, this needs to be done as soon as possible after embedding.

Typical Product Properties (Excerpt*)

DENSOLASTIC®-SU 85 is characterized by the following properties:

- Vibration-reducing
- Chemically and mechanically resistant
- Permanently elastic
- Long-term resistance to temperatures from -20 °C to +70 °C (-4 °F to +158 °F)
- Resistant to water, saline solution (10%), sodium hydroxide solution (5%) and engine oil (SAE 10 W 40)
- Electrically insulating

Pot life	4–5 min. (approx.)	-
Density (cured)	0.88 kg/l (A+B component)	
Shore hardness A	85 ± 5	DIN EN ISO 868
Tear strength	> 4.0 N/mm ²	ISO R 527
Elongation after fracture	>100%	ISO R 527
Volume resistivity	≥ 2 x 10 ¹⁷ Ω x cm	DIN IEC 93
Colour	grau-schwarz	DIN IEC 93

Curing process at +23 °C (+73.4 °F)

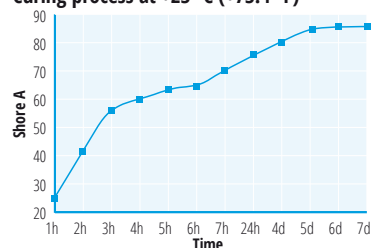

* For more product information as well as details on ordering and packaging, please refer to the product data sheet at denso-group.com.

TOK®-Melt SU

TOK®-Melt SU is a hard elastic, hot-poured compound based on bitumen.

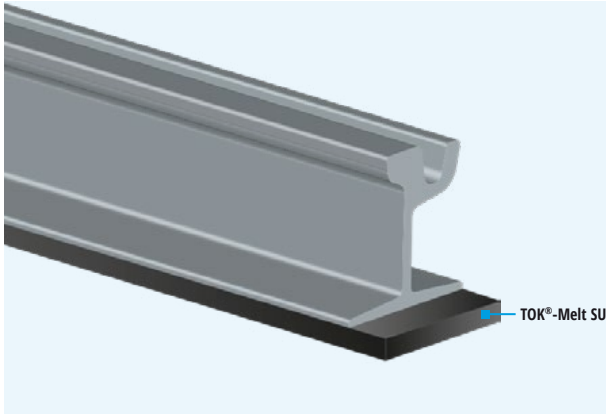

- ✓ Meets the requirements of VDV Notice 6201, 'Bedding for rails'.
- ✓ Vibration-damping.
- ✓ High softening point.

TOK®-Melt SU is a bituminous embedding compound with high stability and surface compression strength.

Based on its hard elasticity, TOK®-Melt SU has vibration damping properties, providing a uniform bearing surface for tram tracks – which also helps to minimize noise production.

Usage

Heating the compound

TOK®-Melt SU must only be heated in melting kettles equipped with a mixer and thermometer. Ensure the product is heated slowly to the working temperature. With simple bitumen heaters without a mixer, there is danger of overheating the compound. This will result in a deterioration or even destruction of the polymers and fillers added to stabilize and enhance the products. The heating of the embedding compound should take place only in kettles that have been cleaned beforehand – i.e. cleaned of burned-on residues. The various sealing compound types must not be mixed together by accident.

Preparatory work on the rail to embedding:

- Establish a fixed track mounting, i.e. underlay the rail with hardwood wedges or steel plates to prevent accidental rail movement downwards.
- Anchor the rail to the substructure with anchor rods (track anchors) to prevent accidental rail movement upwards.
- For pieces of track about 4 or more spans in length (60–70 m), rail gaps should be left to permit steel expansion of the track at daytime temperatures of over +20° C (+68 °F). This reduces the possibility of track movement/longitudinal positional change on the installed embedding compound due to thermal expansion.
- The embedding space near the rail footing should be confined using a barrier of masonry mortar or concrete (for example). The use of a mortar or concrete barrier enables precipitation water to be blown out as necessary; sand barriers (e.g.) have proven unsuitable here. The barrier edge should be approx. 15 mm higher than the rail footing to be embedded.
- Following installation of each embedding compound layer, the space is to be blown clean using compressed air, taking care to ensure the removal of loose detritus and any water present.

Rail application/embedding:

Rail embedding should be carried out in dry weather wherever possible. The embedding compound must not be installed during rain or with standing water under the rail. The building structure should have a surface temperature of at least +5° C (+41 °F). The rail footing is embedded to a thickness of 3.5 to 6 cm using hot pouring. Application involves installing two layers.

Benefits of the two-layer embedding procedure are as follows:

- Steam bubbles – caused solely during the first pour due to the moisture contained in concrete – can escape.
- Different shrinkage settling resulting from different embedding heights – especially due to changes in track height on re-used concrete bedding – is avoided.
- Direct heat transfer into the rail and the setting time of the compound are each reduced/shortened by approx. 50%.

The material installed in the first pour serves to fix the hardwood underlay in place: These are then protected against any permanent yet unnoticed positional changes due to tram operation between the end of the day and the start of the night shift. It also ensures a shortened cooling-off time for the individual layers. This, in turn, ensures a more rapid return to service for the track for urban railway traffic. The embedding compound must have the prescribed temperature for installation. If the working temperature is much lower than required, flow properties will suffer and the compound will not completely fill the rail footing to be embedded. There is thus a danger of cavity formation. The embedding compound should preferably be installed from one side – if tracks are banked, from the side with the lower rail footing position. The first pour should result in a thickness of approx. 60% of the total height to be installed. After the first layer has cooled (warm to the touch), the 'final pour' can then be carried out. The 'final pour' should fill material to the upper edge of the rail footing. If shrink settling occurs, another pour will become necessary. Once embedded, the rails should be covered as soon as possible using the appropriate top material (track covering).

Typical Product Properties (Excerpt*)

Test	Unit
Type	Hot-poured compound
Base	Bitumen
Viscosity	Solid (temperature-dependent thermoplastic)
Density	1.5 g/cm ³ (approx.)
Pouring temperature	+200 to +230 °C (+392 to +446 °F) (approx.) Do not overheat compound!
Colour	Black

* For more product information as well as details on ordering and packaging, please refer to the product data sheet at denso-group.com.





DENSO®-Gleitmittel

A semi-solid compound for use on mechanical seals in concrete pipes and manhole components.

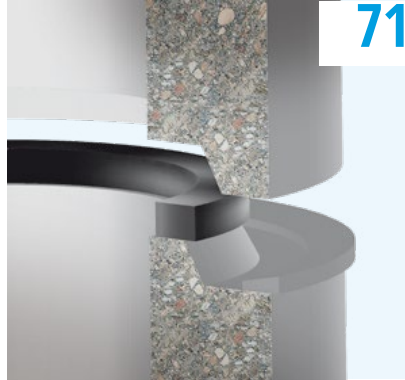

TOK®-Strip

Bitumen and butyl-rubber based plastic, self-adhesive on one side seal for manhole components and special profiles made of concrete.

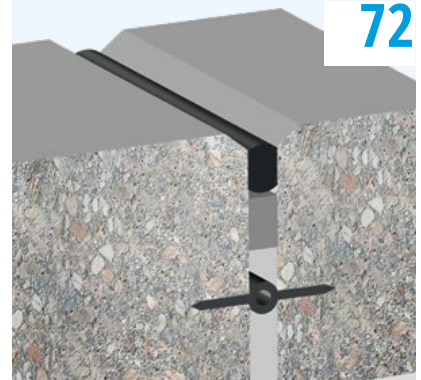

FERMADUR®

Compressions seals made of chloroprene rubber (CR) for UV and ozone stressed joints or styrene butadiene-rubber (SBR) for underground joints.

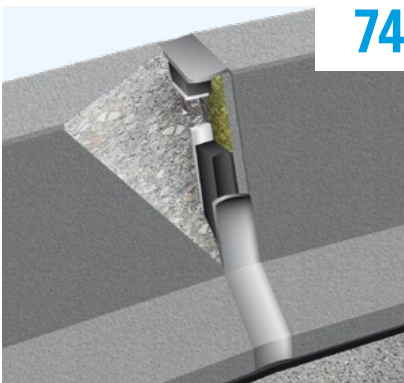

TOK®-BSW System

Bitumen-based, weather-resistant joint compound system for creating permanent seals on joints in concrete protective walls.

DENSO®-Gleitmittel (lubricant)

DENSO®-Gleitmittel (lubricant) is a semi-solid compound for use on mechanical seals in concrete pipes and manhole components.

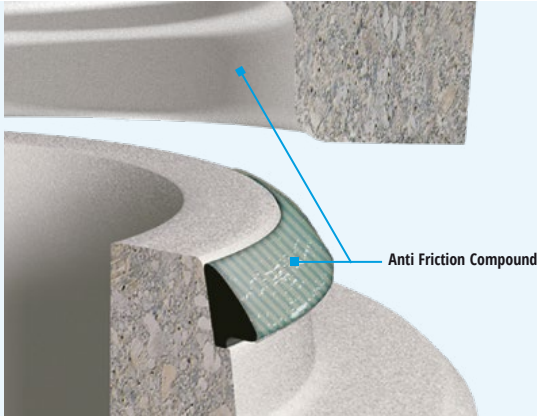

Can be used in cold, heat and rain. Usage temperature ranges from -10 °C to +50 °C (+14 °F to +122 °F).



Optimum lubrication even with rough surfaces.



Environmentally friendly, biodegradable.



Material compatibility with rubber seals – in accordance with DIN EN 681-1.

DENSO®-Gleitmittel (lubricant) consists of a composition of organic materials and inorganic fillers. By applying the lubricant on rubber seals and concrete surfaces, such as is required in sewer construction, the excellent material consistency and shear strength mean

you get a simple and component-protecting merging of spigot and socket, even possible on rough concrete surfaces. As the organic components are biodegradable, there is also a high degree of environmental compatibility provided.

Important information for practical use

In accordance with DIN EN 1610, a compatible lubricant for the components and seals is to be supplied by the pipe and manhole manufacturer. The lubricant developed by DENSO is the result of decades of research and practical experience. Thanks to its special composition, **DENSO®-Gleitmittel** (lubricant) is designed to exactly meet the requirements for laying

concrete and steel-reinforced concrete pipes. Due to its biodegradability, the lubricant has no negative impact on the service life of the seal, as required by DIN EN 681-1 at point 4.1.1.

Application – laying of pipes

DENSO®-Gleitmittel (lubricant) is applied to the concrete sliding surface in the sleeve or on the spigot; it is best to use a glove for this. An additional smearing of the concrete on the spigot end is not normally required, although it does however help minimise the installation force.

DN	with 1 kg of lubricant, approximately the following can be laid
300	12 Pipes
400	9 Pipes
500	7 Pipes
600	5 Pipes
700	5 Pipes
800	4 Pipes
900	4 Pipes
1000	3 Pipes
1200	3 Pipes

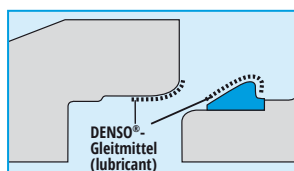
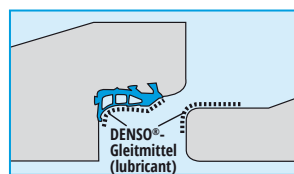

Application – placement of manhole rings

DENSO®-Gleitmittel (lubricant) is applied to the inside of the manhole sleeve (integrated shaft seal) covering it well; it is best to use a glove for this. An additional smearing of the concrete on the spigot end is not normally required, although it does however help minimise the installation force.

DN	with 1 kg of lubricant, approximately the following can be laid
1000	7 manhole rings
1200	3 manhole rings
1500	2 manhole rings

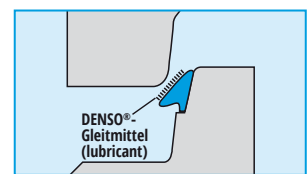





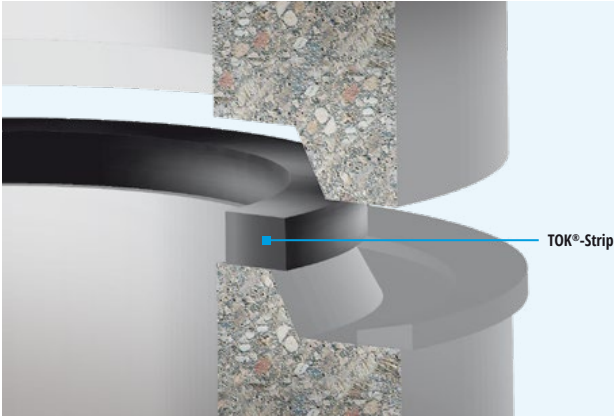

* For more product information as well as details on ordering and packaging, please refer to the product data sheet at denso-group.com.

TOK®-Strip

Bitumen- and butyl rubber-based plastic seal, self-adhesive on one side, for manhole components and specialized concrete section.



-  Very good sealing effect and simple workability.
-  Helps to compensate for unevenness in the finished parts.
-  Good waste water and chemical resistance.
-  Self-adhesive on one side – very good adhesion to concrete.
-  Solvent-free.
-  Withstands water pressure of up to 0.5 bar.

TOK®-Strip is a plastic seal for manhole components and special profiles made of concrete. Due to the combination of bitumen, butyl rubber and other innovative components, as well as the self-adhesive, one-sided coating, the sealing strip adjusts to the existing

geometries, compensates for any unevenness of the component and adheres very well to the contact surfaces.

Usage

TOK®-Strip is mainly used in sewer construction. Wherever elastomer profiles cannot be used, for whatever reasons, tight seals can be created using **TOK®-Strip**. The various cross-sectional dimensions of the strip permit its use in many areas, e.g. as a joint seal for

manhole components placed on top of each other or many other

Application

Subsurface preparation and sealing tape installation

The contact surfaces must be solid, clean, dry and free from any release agents. To achieve better adhesion, we recommend pre-treating the contact surfaces with **TOK®-SK Primer**. This is a plastic resin-based primer. The primer is applied across all surfaces using a brush or with a sprayer. The air drying time in summer is approximately 3 to 5 minutes. After the primer has air dried, the tape – selected for an appropriate cross-section – is applied. Note that the sealing tape is placed without being stretched along its long axis. At the contact ends, the tapes must be placed on each other with a scarf joint so that a tight compression can be achieved. The sealing tape can be installed at ambient temperatures of **-15 °C (+5 °F) to +40 °C (+104 °F)**. At temperatures below +5 °C (+41 °F), we recommend that the tape is stored in an area where the temperature is above +15 °C (+59 °F) before installation.

Installation

The construction components must be centrally aligned to ensure even pressure on the **TOK®-Strip**. The compression of the seal should be between 30% and 50%. The tape thickness must not be less than 10 mm. The sealing tape is not designed for the transfer of vertical loads. This must be achieved using spacers or an additional mortar joint.

Typical Product Properties (Excerpt*)





Technical data	Unit	Value
Colour	-	Black
Density	g /cm ³	1.32 (approx.)
Elastic recovery	%	> 10
Dimensional stability (45 °C, 24 hr.)	mm	≤ 2
Ring and ball softening point	°C / °F	> +90 (+194)

* For more product information as well as details on ordering and packaging, please refer to the product data sheet at denso-group.com.

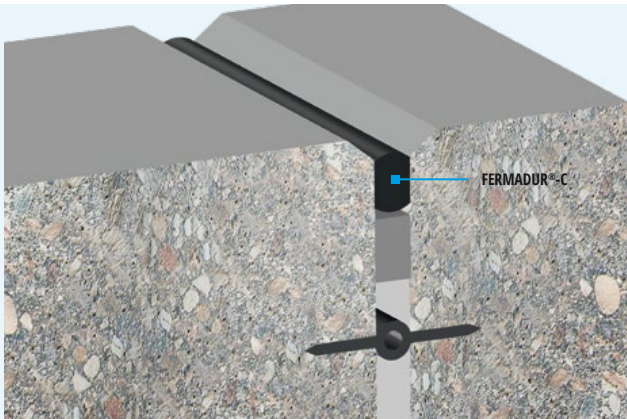
FERMADUR®-C

FERMADUR®-C is a compression seal made of chloroprene rubber (CR) for UV- and ozone-stressed joints.



-  Can be installed in almost any weather conditions.
-  No primer or adhesive is needed.
-  Quick and professional installation by trained personnel.
-  Withstands water pressure of up to 1.0 bar.

FERMADUR®-C is a sealing strip made of vulcanised, cellular rubber with a closed-cell, smooth exterior skin and a circular cross-section. **FERMADUR®-C** seals joints by restoring forces that are created by the deformation of the sealing profile when it is installed in the joint. Bonding to the joint walls is not necessary.

Usage

The **FERMADUR®-C** system is equally suitable for new construction work and restoration work. Typical areas of use include the sealing of working and expansion joints and in civil engineering particularly in:

- Sewage treatment plants
- Locks

Accordingly, **FERMADUR®-C** can be worked with in summer and in winter, in rain or in snow, regardless of the weather conditions. Even with leaky joints under constant water pressure, **FERMADUR®-C** can still be installed and is effective immediately.

- Swimming pools
- Prefabricated building parts
- In bridge-building, at cap/central longitudinal joints

FERMADUR®-C is widely used in industry for collecting pools, retention basins, filling stations and storage areas as a joint seal for substances hazardous to drinking water.

Application

Important requirements to ensure the sealing effect of **FERMADUR®-C** are minimum and total deformation. The joint to be sealed must therefore be measured and surveyed exactly. When calculating strip parameters, the expected changes to the joint width from the component movements and the water pressure acting on the joint must be taken into account. In addition, the structural design of the joint and the surface of the components must be in accordance with DIN 18 540, sheet 1: "Internal joint surfaces must run parallel to a depth of $D=2xW$." In the joint areas, the concrete must be so impermeable to water that no water circulation can occur at the expected water pressure.

In addition, the joint walls must be even and clean, and must not exhibit chipping or cavities over a depth twice that of the joint width. If necessary, improvements to the concrete or mortar can be made using silicification or impregnation.

The application temperature range is from -10 °C to $+50\text{ °C}$ ($+14\text{ °F}$ to 122 °F). Connection points and crossing points are connected or glued using SICOMET 8300. The adhesive must be stored in a cool place (also at the construction site). **FERMADUR®-C** can be installed by hand or with a machine. The joint gap width should not be less than 15 mm and not exceed 35 mm.

Sealing work using **FERMADUR®-C** strips must be carried out by well-trained and experienced specialist personnel. As a rule, work is usually carried out by contractors whose employees have been trained by DENSO GmbH.

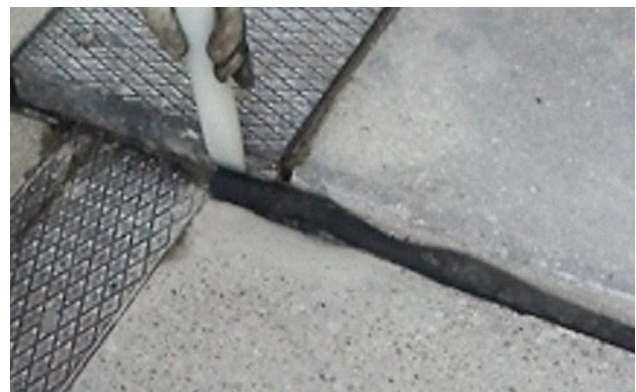

Typical Product Properties (Excerpt*)

Properties	Unit	Value
Tensile strength	N/mm ²	≥3
Elongation after fracture	%	≥150
Recovery tension (15 min. at +23 °C/+73.4 °F, 25% deformation)	N/mm ²	0.20 – 0.40
Compression set (after 24 hr. storage at +70 °C/+158 °F)	%	≤27

The water pressure resistance of the installed **FERMADUR®-C** strip was tested on a DN 1800 pipe fitting under the supervision of MPA Dortmund. The test was performed without a factory-fitted sleeve seal and without the compression seal strip being braced to the rear. Installation and dimensioning were performed in accordance with the manufacturer's





instructions by a trained specialist company. Under these conditions, it was determined that a water pressure resistance of up to 1.0 bar can be achieved. A corresponding test report is available.

*** For more product information as well as details on ordering and packaging, please refer to the product data sheet at denso-group.com.**

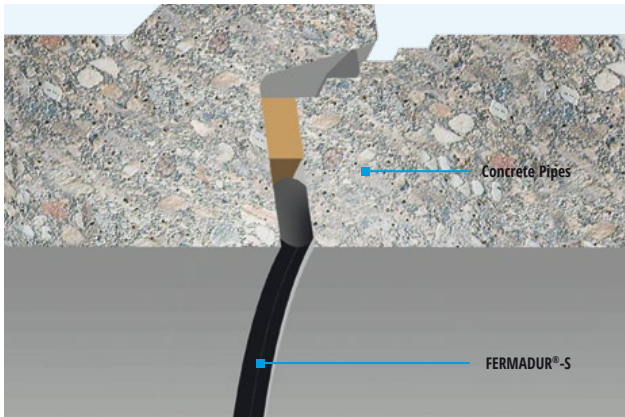
FERMADUR®-S

FERMADUR®-S is a compression seal for underground joints made of styrene butadiene-rubber (SBR).



-  Installation in almost any weather conditions.
-  No primer or adhesive is needed.
-  Quick and professional installation by trained personnel.
-  Withstands water pressure of up to 1.0 bar.

FERMADUR®-S is a sealing strip made of vulcanized, cellular rubber with a closed-cell, smooth exterior skin and a circular cross-section. FERMADUR®-S seals joints by restoring forces that are created by the deformation of the sealing profile when it is installed in the joint.

Bonding to the joint walls is not necessary. Accordingly, FERMADUR®-S can be worked with in summer and in winter, in rain or in snow, regardless of the weather conditions. Even with leaky joints!

Usage

The FERMADUR®-S system is equally suitable for new construction work and restoration work. Typical areas of use include the sealing of working and expansion joints and in civil

engineering in particular. The product is suitable only for joint types that are not exposed to direct UV or ozone loads.

Application

Important requirements to ensure the sealing effect of FERMADUR®-S are minimum and total deformation. The joint to be sealed must therefore be measured and surveyed exactly. When calculating strip parameters, the expected changes to the joint width from the component movements and the water pressure acting on the joint must be taken into account. In addition, the structural design of the joint and the surface of the components must be in accordance with DIN 18 540, sheet 1: "Internal joint surfaces must run parallel to a depth of $D=2xW$." In the joint areas, the concrete must be so impermeable to water that no water circulation can occur at the expected water pressure.

In addition, the joint walls must be even and clean, and must not exhibit chipping or cavities over a depth twice that of the joint width. If necessary, improvements to the concrete or mortar can be made using silicification or impregnation.

The application temperature range is from -10 °C to +50 °C (+14 °F to 122 °F). Junction points and crossing points are connected or glued using SICOMET 8300. The adhesive must be stored in a cool place (also at the construction site). The adhesive is only used as an installation aid during installation.

FERMADUR®-S can be installed by hand or with a machine. The joint gap width should not be less than 15 mm and not exceed 35 mm. Sealing work using FERMADUR®-S strips must be carried out by well-trained and experienced specialist personnel. As a rule, work is usually carried out by contractors whose employees have been trained by DENSO GmbH.



Typical Product Properties (Excerpt*)

Properties	Unit	Value
Tensile strength	N/mm ²	≥ 3
Elongation after fracture	%	≥ 350
Recovery tension (15 min. at 23 °C/73.4 °F, 25% deformation)	N/mm ²	0,20 – 0,40
Compression set (after 24 hr. storage at 70 °C/158 °F)	%	≤ 20

The water pressure resistance of the installed FERMADUR®-S strip was tested on a DN 1800 pipe fitting under the supervision of MPA Dortmund. The test was performed without a factory-fitted sleeve seal and without the compression seal strip being braced to the rear.

Installation and dimensioning were performed in accordance with the manufacturer's instructions by a trained specialist company. Under these conditions, it was determined that a water pressure resistance of up to 1.0 bar can be achieved. A corresponding test report is available.

*** For more product information as well as details on ordering and packaging, please refer to the product data sheet at denso-group.com.**

TOK®-BSW System

System consisting of bituminous joint compound and weather-resistant protective layer for the permanent sealing of joints in concrete safety barriers.

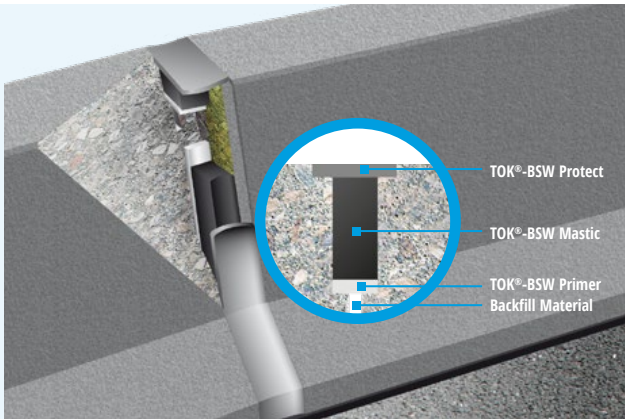

- ✓ Component-matched system.
- ✓ Long-lasting and weather-resistant.
- ✓ UV- and ozone-resistant.
- ✎ Simple to work with.
-  The joint compound meets the requirements of DIN EN 14188 Part 1, type N2.

The TOK®-BSW is a joint sealing system for joints in concrete safety barriers. The system consists of individual components perfectly matched to one another: TOK®-BSW Primer as the primer for the joint compound, TOK®-BSW Mastic, a high-performance, modified bituminous compound, and TOK®-BSW Protect, an extremely weather-resistant, highly-

modified bituminous compound. These compounds have been successfully used for many years in comparable products and have established a solid reputation in the industry as durable protection systems.

Usage

The TOK®-BSW is typically used for joint sealing in concrete safety barriers. A combination of an elastic filling material and a weather-resistant protective layer ensures the level of

safety necessary for a durable and highly functional joint sealing in safety-conscious applications.

Application

General instructions

As a rule, the joint compound should only be installed in dry conditions and where joint surface temperatures are at least 0 °C (+32 °F). The maximum surface temperature should not exceed +40 °C (+104 °F).

Preparing the joints

The concrete must be dry, clean, and free from loose parts or release agents. Concrete must be at least 7 days old and have attained at least 70% of its 28-day compressive strength at the time of jointing. Coated surfaces must be pre-treated. In accordance with ZTV FRS, the recommended joint width is 10 mm. We recommend a joint width of 15 mm. Joint flanges must run exactly parallel to one another. In accordance with ZTV Fug-StB, the recommended joint depth for concrete joints is at least 1.5x the joint gap width and is also dependent on expected changes in the joint gap width. We recommend a joint fill depth of 25 mm. In all cases, "three-surface adhesion", i.e. bonding of the joint sealant to the subsurface (and not to the joint flanges!) must be avoided. In addition, an appropriate heat-resistant lining must be used in accordance with ZTV Fug-StB (e.g. silicone paper or cord seal, etc.). Further details about measuring joint cross-sections and about suitable linings can be obtained by consulting ZTV Fug-StB.

Application of TOK®-BSW Primer

Following the proper and correct pretreatment of the flanges, TOK®-BSW Primer is applied across all contact surfaces. In summer, the air drying time is approx. 3–5 minutes. After the primer has air-dried, the lining is inserted into the joint.

Installation of TOK®-BSW Mastic

The application of TOK®-BSW Mastic involves the use of specialized equipment. The material bars are filled into cartridges (600 ml) by an extrusion machine. Immediately after filling, the sealant material is then inserted into the vertical joints. The material must be worked relatively quickly, so that the heated compound can be easily pressed out of the cartridge. Once the material has been completely pressed out of the cartridge, new material can easily be filled and work can then proceed immediately. The sealant ends approx. 3 mm before the outer edge of the concrete, to leave enough space for the protective layer.

Installation of TOK®-BSW Protect

To provide additional protection, the TOK®-BSW Mastic joint filler receives a layer of TOK®-BSW Protect. This compound is also installed using the same type of equipment that was used to process the TOK®-BSW Mastic. Only the nozzle technology on the cartridge gun is different – to ensure that the compound can be applied so it is flush to the surface of the concrete barrier.

Further benefits of the TOK®-BSW:

Reworking

The system offers a major advantage when carrying out minor repair work. In this case, existing compound can be non-destructively heated, covered with new compound and then trowelled smooth.

Renovation work

TOK®-BSW can also be utilized for renovation work on existing joints. Here, the same general preconditions apply as for new construction work. Renovation work must ensure that all residues of old joint fillers have been removed and joint widths must be widened to at least 15 mm.

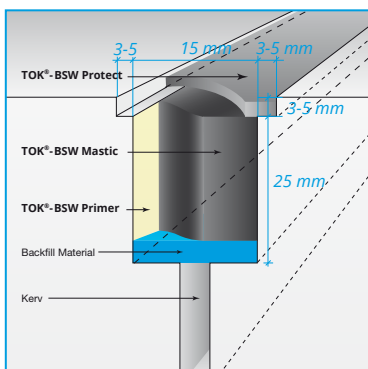

* For more product information as well as details on ordering and packaging, please refer to the product data sheet at denso-group.com.

SAFE ROADS WITH TOK[®]-BSW SYSTEM



Long-lasting weather protection
TOK[®]-BSW System

At least **25 Years**
weather resistant



ADVANCED IN SEALING.



History

DENSO Group Germany

DENSO (derived from the Latin word "densus", which means "seal") stands for high-quality sealing solutions for corrosion prevention and road construction. Since it was founded in 1922, DENSO has evolved from a family company to an international group, with subsidiaries in six European countries and over 100 sales partners around the world.

Chemieprodukte GmbH founded

14.11.1922: Against the backdrop of a post-war Germany that is suffering from famine, hyperinflation and unemployment, the company lays the foundations for its future global success story in Berlin

1922



From the Spree to the Rhine

1950: After the destruction of the company's original premises during the Second World War, the company reforms in Leverkusen. The proximity of the new site to BAYER AG and the Rhine river provides the inspiration for new inventions – and an efficient transport route.

1950



1952



TOK®-Band: Duality provides balance

1952: A second product puts the company on a stable footing. The invention of TOK®-Band for sewer construction enables DENSO to successfully enter a new market.

DENSOLEN®:

A tape becomes a hose

1973: DENSO invents the world's first co-extruded three-ply tape for preventing corrosion around welded joints on pipelines.

1973



1977



TOK®-Band Spezial: Taking quality to the roads

1977: The new TOK®-Band Spezial revolutionises road construction and becomes a synonym for bitumen joint tape.



Invention of DENSO®-Tape

1927: As the world's first petrolatum tape, the DENSO®-Tape becomes a generic synonym for reliable passive corrosion prevention for pipelines.



The company's innovative product and system solutions help to ensure safe energy transport and durable roads. The protection of people, the environment and resources has the top priority for DENSO's team of around 200 employees. In pipeline construction, DENSO products ensure that pipelines can be operated reliably and without interruption for decades. In road construction,

DENSO is a leading innovator in the sealing of joints in asphalt and concrete. The company's high-performance products reduce construction time while also improving health and safety and environmental performance.

DENSO always thinks ahead. And we've been doing it for 100 years.

TOKOMAT®:

Construction site efficiency

1994: Thanks to the new application device, bitumen joint tapes can now be machine-extruded directly on the construction site for the first time.

1994



TOK®-Sil Resist:

Groundwater protection against acids

2013: The acid-resistant TOK®-Sil Resist is a new innovation for biogas and liquid manure, slurry and silage effluent plants.

2013

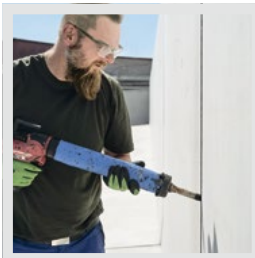

TOK®-Band A:

Improving on what we already have. Developing new innovations.

2017: TOK®-Band bitumen joint tapes can now often be applied without using a primer. The activatable TOK®-Band A can be applied in a matter of seconds.

2017

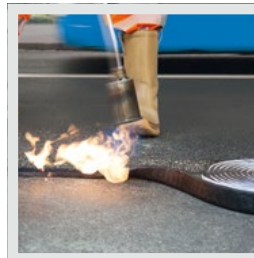

100 Jahre DENSO:

Invent, seal & celebrate!

2022: We are thankful for and proud of everything we have achieved. With our innovative products and a strong team, we're looking to the future with confidence.

2022



2006



Entering new markets with DEKOTEC® heat shrinkable sleeves

2006: Thanks to its innovative hot-melt and mastic technology, the product boasts exceptionally high resistance in all temperature ranges.

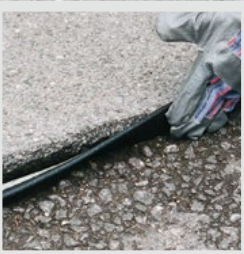

The self-adhesive TOK®-Band SK: An innovation for road construction

1996: No flame is required to apply the first ever self-adhesive sealing tape.

SEALID®: A new simplicity in corrosion prevention

2021: DENSO launches SEALID®, the world's first primerless All-in-1 solution

DENSO ONLINE

Are you not yet sure which product is ideal for your requirements? Find it quickly with our extended product finder on denso-group.com !

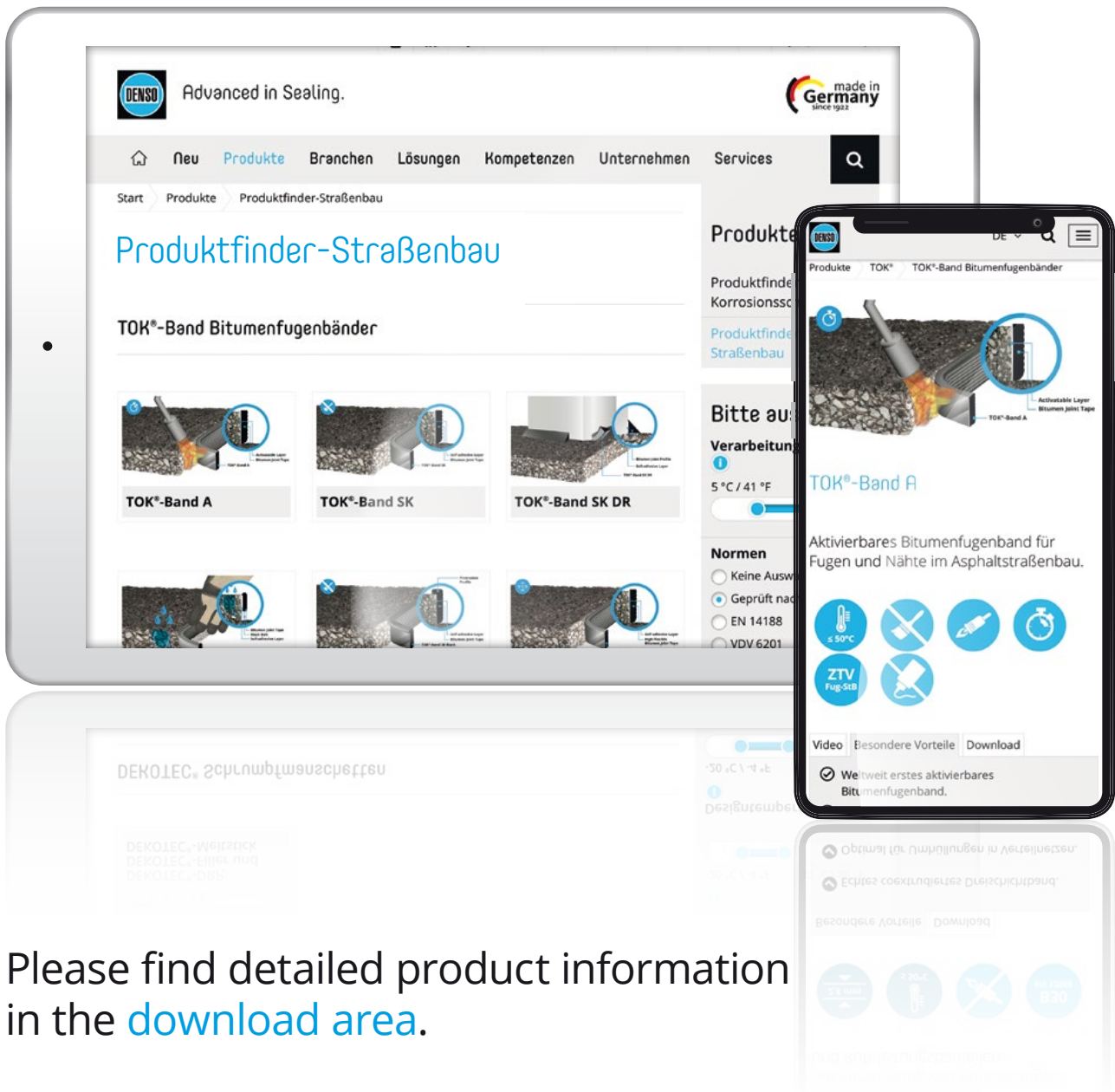

Please find detailed product information in the [download area](#).

ROAD CONSTRUCTION

Get to know our products for road construction online at denso-group.com or in the brochure "**Corrosion Prevention – We preserve values**".



SEALID®
All-in-1 Solution



DENSOLEN®
PE/Butyl-Tapes & Systems



DENSO®
Petrolatum Tapes & Mastics



DEKOTEC®
Heat Shrinkable Sleeves



VivaxCoat®
Protection Systems for Wet Surfaces



DENSIT®
Insulation & Sealing Tapes

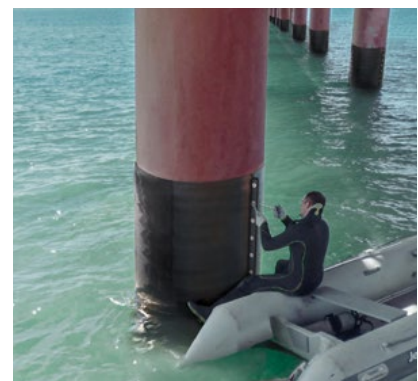

MarineProtect®
Pier & Harbour Protection



Find us here:

DENSO GmbH

Felderstraße 24
51371 Leverkusen / Germany
Phone +49 214 2602-0

DEKOTEC GmbH

Felderstraße 24
51371 Leverkusen / Germany
Phone +49 214 2602-0 / dekotec.com

DENSOKOR AG

Bahnhofstrasse 36
5502 Hunzenschwil / Switzerland
Phone +41 43 3662244

DENSO France S.A.R.L.

43/45, Rue Jean Jaurés
92300 Levallois-Perret / France
Phone +33 1 41400088

DENSO Dichtungstechnik

Franzensthalstraße 27
2435 Ebergassing / Austria
Phone +43 2234 750
GmbH & Co. KG

DENSO QUIMICA S.A.U.

Apdo. Correos 18 Yunque, 9-11 Nave 12A
28760 Tres Cantos (Madrid) / Spain
Phone +34 91 8064254

Imbema DENSO B.V.

Mauritsstraat 5-7 Postbus 160
2000 AD Haarlem / The Netherlands
Phone +31 23 5172424

Imbema DENSO N.V./S.A.

Industrieweg 25
9420 Erpe-Mere / Belgium
Phone +32 53805172

info@denso-group.com

denso-group.com

DENSO GmbH

Felderstraße 24 | 51371 Leverkusen | Germany
Phone: +49 214 2602-0 | info@denso-group.com
www.denso-group.com

Our product information, application recommendations and other printed publications provide advice to the best of our knowledge and indicate our level of knowledge at the time of printing. The content is not legally binding. Therefore, no liability is assumed for incorrect and missing advice. The applicator is obliged to check the suitability and possibility of application for the intended purpose. Unless otherwise specified, all of the brands named are trademarks of DENSO, at least registered in Germany, which are

protected by law. Only our general terms and conditions of sale, which you will find at www.denso-group.com, apply. This is a translation from the original German product information. In case of any discrepancy or any dispute arising on the interpretation, the German text of the respective German product information, which is available at www.denso-group.com, shall be decisive. The legal relationship shall be governed by German law.

04.2023